

SECTION **BRC**

BRAKE CONTROL SYSTEM

A
B
C
D
E

CONTENTS

| | | |
|--|--|------------|
| | | |
| VDC/TCS/ABS | | BRC |
| PRECAUTION | DIAGNOSIS SYSTEM [ABS ACTUATOR AND ELECTRIC UNIT (CONTROL UNIT)] | 32 |
| | CONSULT Function (ABS) | 32 |
| PRECAUTIONS | ECU DIAGNOSIS INFORMATION | 36 |
| Precaution for Supplemental Restraint System (SRS) "AIR BAG" and "SEAT BELT PRE-TENSIONER" | ABS ACTUATOR AND ELECTRIC UNIT (CONTROL UNIT) | 36 |
| Precaution for Procedure without Cowl Top Cover..... | Reference Value | 36 |
| Precaution for Brake System | Fail-safe | 39 |
| Precaution for Brake Control | DTC Inspection Priority Chart | 42 |
| Precaution for CAN System | DTC Index | 42 |
| PREPARATION | WIRING DIAGRAM | 44 |
| | BRAKE CONTROL SYSTEM | 44 |
| PREPARATION | Wiring Diagram | 44 |
| Special Service Tool | BASIC INSPECTION | 51 |
| Commercial Service Tool | DIAGNOSIS AND REPAIR WORK FLOW | 51 |
| SYSTEM DESCRIPTION | Work Flow | 51 |
| | Diagnostic Work Sheet | 52 |
| COMPONENT PARTS | ADDITIONAL SERVICE WHEN REPLACING ABS ACTUATOR AND ELECTRIC UNIT (CONTROL UNIT) | 53 |
| Component Parts Location | Description | 53 |
| Component Description | Work Procedure | 53 |
| ABS Actuator and Electric Unit (Control Unit) | ADJUSTMENT OF STEERING ANGLE SENSOR NEUTRAL POSITION | 54 |
| Wheel Sensor and Sensor Rotor | Description | 54 |
| Stop Lamp Switch | Work Procedure | 54 |
| Steering Angle Sensor | DTC/CIRCUIT DIAGNOSIS | 56 |
| VDC OFF Switch | C1101, C1102, C1103, C1104 WHEEL SENSOR | 56 |
| Brake Fluid Level Switch | DTC Logic | 56 |
| Parking Brake Switch | Diagnosis Procedure | 56 |
| SYSTEM | | |
| VDC/TCS/ABS | | |
| VDC/TCS/ABS : System Diagram | | |
| VDC/TCS/ABS : System Description | | |
| VDC/TCS/ABS : VDC Function | | |
| VDC/TCS/ABS : TCS Function | | |
| VDC/TCS/ABS : ABS Function | | |
| VDC/TCS/ABS : EBD Function | | |
| VDC/TCS/ABS : Fail-safe | | |

G
H
I
J
K
L
M
N
O
P

| | | | |
|--|-----------|---|-----------|
| C1105, C1106, C1107, C1108 WHEEL SENSOR | 58 | C1155 BR FLUID LEVEL LOW | 81 |
| DTC Logic | 58 | DTC Logic | 81 |
| Diagnosis Procedure | 58 | Diagnosis Procedure | 81 |
| | | Component Inspection | 82 |
| C1109 POWER AND GROUND SYSTEM | 60 | C1164, C1165, C1166, C1167 CV/SV SYSTEM | 83 |
| DTC Logic | 60 | DTC Logic | 83 |
| Diagnosis Procedure | 60 | Diagnosis Procedure | 83 |
| C1110, C1153, C1170 ABS ACTUATOR AND ELECTRIC UNIT (CONTROL UNIT) | 62 | U1000 CAN COMM CIRCUIT | 85 |
| DTC Logic | 62 | DTC Logic | 85 |
| Diagnosis Procedure | 62 | Diagnosis Procedure | 85 |
| C1111 PUMP MOTOR | 63 | U1002 SYSTEM COMM (CAN) | 86 |
| DTC Logic | 63 | DTC Logic | 86 |
| Diagnosis Procedure | 63 | Diagnosis Procedure | 86 |
| C1115 ABS SENSOR [ABNORMAL SIGNAL] .. | 65 | PARKING BRAKE SWITCH | 87 |
| DTC Logic | 65 | Component Function Check | 87 |
| Diagnosis Procedure | 65 | Diagnosis Procedure | 87 |
| C1116 STOP LAMP SWITCH | 67 | Component Inspection | 88 |
| DTC Logic | 67 | VDC OFF SWITCH | 89 |
| Diagnosis Procedure | 67 | Component Function Check | 89 |
| C1120, C1122, C1124, C1126 ABS IN VALVE SYSTEM | 69 | Diagnosis Procedure | 89 |
| DTC Logic | 69 | Component Inspection | 90 |
| Diagnosis Procedure | 69 | ABS WARNING LAMP | 91 |
| C1121, C1123, C1125, C1127 ABS OUT VALVE SYSTEM | 71 | Component Function Check | 91 |
| DTC Logic | 71 | Diagnosis Procedure | 91 |
| Diagnosis Procedure | 71 | BRAKE WARNING LAMP | 92 |
| C1130 ENGINE SIGNAL | 73 | Component Function Check | 92 |
| DTC Logic | 73 | Diagnosis Procedure | 92 |
| Diagnosis Procedure | 73 | VDC OFF INDICATOR LAMP | 93 |
| C1140 ACTUATOR RELAY SYSTEM | 74 | Component Function Check | 93 |
| DTC Logic | 74 | Diagnosis Procedure | 93 |
| Diagnosis Procedure | 74 | SLIP INDICATOR LAMP | 94 |
| C1142 PRESS SENSOR | 76 | Component Function Check | 94 |
| DTC Logic | 76 | Diagnosis Procedure | 94 |
| Diagnosis Procedure | 76 | SYMPTOM DIAGNOSIS | 95 |
| C1143 STEERING ANGLE SENSOR | 77 | VDC/TCS/ABS | 95 |
| DTC Logic | 77 | Symptom Table | 95 |
| Diagnosis Procedure | 77 | EXCESSIVE ABS FUNCTION OPERATION FREQUENCY | 96 |
| C1144 INCOMPLETE STEERING ANGLE SENSOR ADJUSTMENT | 79 | Diagnosis Procedure | 96 |
| DTC Logic | 79 | UNEXPECTED PEDAL REACTION | 97 |
| Diagnosis Procedure | 79 | Diagnosis Procedure | 97 |
| C1145, C1146 YAW RATE/SIDE/DECEL G SENSOR | 80 | THE BRAKING DISTANCE IS LONG | 98 |
| DTC Logic | 80 | Diagnosis Procedure | 98 |
| Diagnosis Procedure | 80 | ABS FUNCTION DOES NOT OPERATE | 99 |
| | | Diagnosis Procedure | 99 |

| | | |
|---|------------|---|
| PEDAL VIBRATION OR ABS OPERATION | | |
| SOUND OCCURS | 100 | |
| Diagnosis Procedure | 100 | |
| VEHICLE JERKS DURING VDC/TCS/ABS | | |
| CONTROL | 101 | |
| Diagnosis Procedure | 101 | |
| NORMAL OPERATING CONDITION | 102 | |
| Description | 102 | |
| REMOVAL AND INSTALLATION | 103 | |
| WHEEL SENSOR | 103 | |
| FRONT WHEEL SENSOR | 103 | |
| FRONT WHEEL SENSOR : Exploded View | 103 | |
| FRONT WHEEL SENSOR : Removal and Installation | 103 | |
| REAR WHEEL SENSOR | 104 | |
| REAR WHEEL SENSOR : Exploded View | 104 | |
| | | REAR WHEEL SENSOR : Removal and Installation |
| | | 104 |
| | | SENSOR ROTOR |
| | | 106 |
| | | FRONT SENSOR ROTOR |
| | | 106 |
| | | FRONT SENSOR ROTOR : Removal and Installation |
| | | 106 |
| | | REAR SENSOR ROTOR |
| | | 106 |
| | | REAR SENSOR ROTOR : Removal and Installation |
| | | 106 |
| | | ABS ACTUATOR AND ELECTRIC UNIT |
| | | (CONTROL UNIT) |
| | | 107 |
| | | Exploded View |
| | | 107 |
| | | Removal and Installation |
| | | 107 |
| | | VDC OFF SWITCH |
| | | 109 |
| | | Removal and Installation |
| | | 109 |
| | | STEERING ANGLE SENSOR |
| | | 110 |
| | | Removal and Installation |
| | | 110 |

A
B
C
D
E
BRC
G
H
I
J
K
L
M
N
O
P

PRECAUTION

PRECAUTIONS

Precaution for Supplemental Restraint System (SRS) "AIR BAG" and "SEAT BELT PRE-TENSIONER"

INFOID:000000007673949

The Supplemental Restraint System such as "AIR BAG" and "SEAT BELT PRE-TENSIONER", used along with a front seat belt, helps to reduce the risk or severity of injury to the driver and front passenger for certain types of collision. This system includes seat belt switch inputs and dual stage front air bag modules. The SRS system uses the seat belt switches to determine the front air bag deployment, and may only deploy one front air bag, depending on the severity of a collision and whether the front occupants are belted or unbelted. Information necessary to service the system safely is included in the SR and SB section of this Service Manual.

WARNING:

- To avoid rendering the SRS inoperative, which could increase the risk of personal injury or death in the event of a collision which would result in air bag inflation, all maintenance must be performed by an authorized NISSAN/INFINITI dealer.
- Improper maintenance, including incorrect removal and installation of the SRS, can lead to personal injury caused by unintentional activation of the system. For removal of Spiral Cable and Air Bag Module, see the SR section.
- Do not use electrical test equipment on any circuit related to the SRS unless instructed to in this Service Manual. SRS wiring harnesses can be identified by yellow and/or orange harnesses or harness connectors.

PRECAUTIONS WHEN USING POWER TOOLS (AIR OR ELECTRIC) AND HAMMERS

WARNING:

- When working near the Airbag Diagnosis Sensor Unit or other Airbag System sensors with the Ignition ON or engine running, DO NOT use air or electric power tools or strike near the sensor(s) with a hammer. Heavy vibration could activate the sensor(s) and deploy the air bag(s), possibly causing serious injury.
- When using air or electric power tools or hammers, always switch the Ignition OFF, disconnect the battery, and wait at least 3 minutes before performing any service.

Precaution for Procedure without Cowl Top Cover

INFOID:000000007207972

When performing the procedure after removing cowl top cover, cover the lower end of windshield with urethane, etc to prevent damage to windshield.

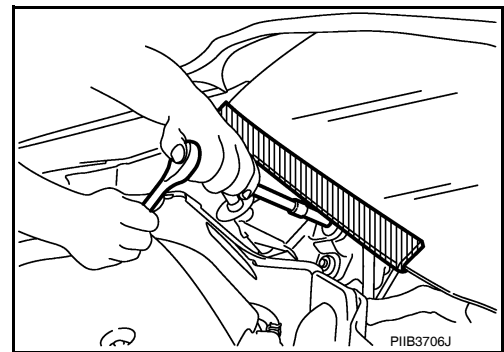

Precaution for Brake System

INFOID:000000007673950

CAUTION:

- Refer to [MA-12, "Fluids and Lubricants"](#) for recommended brake fluid.
- Never reuse drained brake fluid.
- Be careful not to splash brake fluid on painted areas; it may cause paint damage. If brake fluid is splashed on painted areas, wash it away with water immediately.
- To clean or wash all parts of master cylinder and disc brake caliper, use clean brake fluid.
- Never use mineral oils such as gasoline or kerosene. They will ruin rubber parts of the hydraulic system.

PRECAUTIONS

[VDC/TCS/ABS]

< PRECAUTION >

- Use flare nut wrench when removing and installing brake tube.
- If a brake fluid leak is found, the part must be disassembled without fail. Then it has to be replaced with a new one if a defect exists.
- Turn the ignition switch OFF and remove the connector of the ABS actuator and electric unit (control unit) or the battery terminal before performing the work.
- Always torque brake lines when installing.

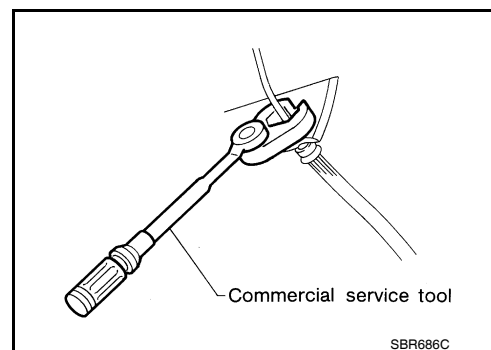

Precaution for Brake Control

INFOID:000000007673951

- During ABS operation, the brake pedal may vibrate lightly and a mechanical noise may be heard. This is normal.
- Just after starting vehicle, the brake pedal may vibrate or a motor operating noise may be heard from engine compartment. This is a normal status of operation check.
- Stopping distance may be longer than that of vehicles without ABS when vehicle drives on rough, gravel, or snow-covered (fresh, deep snow) roads.
- When an error is indicated by ABS or another warning lamp, collect all necessary information from customer (what symptoms are present under what conditions) and check for simple causes before starting diagnosis. Besides electrical system inspection, check booster operation, brake fluid level, and fluid leaks.
- If incorrect tire sizes or types are installed on the vehicle or brake pads are not Genuine NISSAN parts, stopping distance or steering stability may deteriorate.
- If there is a radio, antenna or related wiring near control module, ABS function may have a malfunction or error.
- If aftermarket parts (car stereo, CD player, etc.) have been installed, check for incidents such as harness pinches, open circuits or improper wiring.
- If the following components are replaced with non-genuine components or modified, the VDC OFF indicator lamp and SLIP indicator lamp may turn on or the VDC system may not operate properly. Components related to suspension (shock absorbers, struts, springs, bushings, etc.), tires, wheels (exclude specified size), components related to brake system (pads, rotors, calipers, etc.), components related to engine (muffler, ECM, etc.), components related to body reinforcement (roll bar, tower bar, etc.).
- Driving with broken or excessively worn suspension components, tires or brake system components may cause the VDC OFF indicator lamp and the SLIP indicator lamp to turn on, and the VDC system may not operate properly.
- When the TCS or VDC is activated by sudden acceleration or sudden turn, some noise may occur. The noise is a result of the normal operation of the TCS and VDC.
- When driving on roads which have extreme slopes (such as mountainous roads) or high banks (such as sharp curves on a freeway), the VDC may not operate normally, or the VDC warning lamp and the SLIP indicator lamp may turn on. This is not a problem if normal operation can be resumed after restarting the engine.
- Sudden turns (such as spin turns, acceleration turns), drifting, etc. with VDC turned off may cause the yaw rate/side/decel G sensor to indicate a problem. This is not a problem if normal operation can be resumed after restarting the engine.

Precaution for CAN System

INFOID:000000007673952

- Do not apply voltage of 7.0V or higher to terminal to be measured.
- Maximum open terminal voltage of tester in use must be less than 7.0V.
- Before checking harnesses, turn ignition switch OFF and disconnect battery negative cable.

PRECAUTIONS

[VDC/TCS/ABS]

< PRECAUTION >

- Area to be repaired must be soldered and wrapped with tape. Make sure that fraying of twisted wire is within 110 mm (4.33 in).

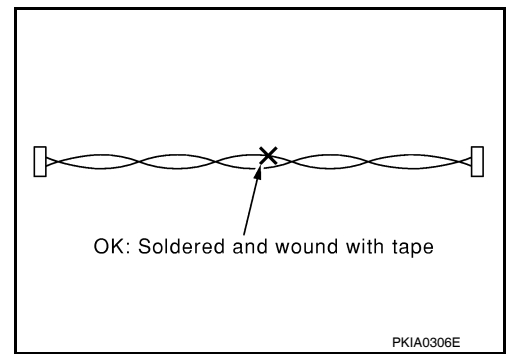

- Do not make a bypass connection to repaired area. (If the circuit is bypassed, characteristics of twisted wire will be lost.)

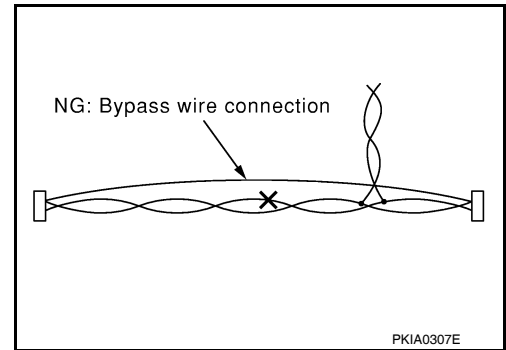

PREPARATION

< PREPARATION >

[VDC/TCS/ABS]

PREPARATION

PREPARATION

Special Service Tool

INFOID:000000007630965

The actual shapes of Kent-Moore tools may differ from those of special service tools illustrated here.

| Tool number (Kent-Moore No.) Tool name | Description |
|--|---|
| — (J-45741) ABS active wheel sensor tester | Checking operation of ABS active wheel sensor |

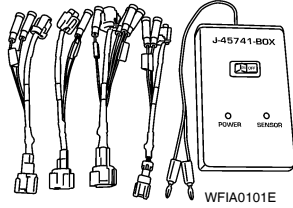

A

B

C

D

E

BRC

Commercial Service Tool

INFOID:000000007630966

| Tool name | Description |
|---|---|
| 1. Flare nut crowfoot 2. Torque wrench | Removing and installing brake piping a: 10mm (0.39 in)/12mm (0.47 in) |

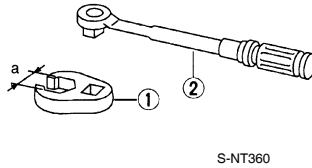

G

H

I

J

K

L

M

N

O

P

COMPONENT PARTS

< SYSTEM DESCRIPTION >

[VDC/TCS/ABS]

| | | | | | |
|----|--|----|----------------------------|---|--|
| 1 | ABS actuator and electric unit (control unit) | 2 | IPDM E/R | 3 | Brake fluid level switch (view with IPDM E/R removed) |
| 4 | Front wheel sensor | 5 | Rear wheel sensor | 6 | VDC OFF switch |
| 7 | Steering angle sensor (view with steering wheel and spiral cable removed) | 8 | Stop lamp switch | 9 | Parking brake switch (view with console removed) |
| 10 | Combination meter (type B) | 11 | Combination meter (type A) | | |

Component Description

INFOID:000000007616445

| Component | Reference/Function |
|---|---|
| ABS actuator and electric unit (control unit) | BRC-9. "ABS Actuator and Electric Unit (Control Unit)" |
| Wheel sensor | BRC-10. "Wheel Sensor and Sensor Rotor" |
| Stop lamp switch | BRC-10. "Stop Lamp Switch" |
| Steering angle sensor | BRC-10. "Steering Angle Sensor" |
| VDC OFF switch | BRC-10. "VDC OFF Switch" |
| Brake fluid level switch | BRC-11. "Brake Fluid Level Switch" |
| Parking brake switch | BRC-11. "Parking Brake Switch" |
| ABS warning lamp | BRC-12. "VDC/TCS/ABS : System Description" |
| Brake warning lamp | |
| VDC OFF indicator lamp | |
| SLIP indicator lamp | |
| ECM | Transmits the following signals to ABS actuator and electric unit (control unit) via CAN communication. <ul style="list-style-type: none"> • Accelerator pedal position signal • Engine speed signal • Target throttle position signal |
| TCM | Transmits the current gear position signal to ABS actuator and electric unit (control unit) via CAN communication. |

ABS Actuator and Electric Unit (Control Unit)

INFOID:000000007616446

Electric unit (control unit) is integrated with actuator and comprehensively controls VDC function, TCS function, ABS function and EBD function.

ELECTRIC UNIT (CONTROL UNIT)

- Brake fluid pressure is controlled according to signals from each sensor.
- If malfunction is detected, the system enters fail-safe mode.

ACTUATOR

The following components are integrated with ABS actuator.

Pump

Returns the brake fluid reserved in reservoir to master cylinder by reducing pressure.

Motor

Activates the pump according to signals from ABS actuator and electric unit (control unit).

Motor Relay

Operates the motor ON/OFF according to signals from ABS actuator and electric unit (control unit).

Actuator Relay (Main Relay)

Operates each valve ON/OFF according to signals from ABS actuator and electric unit (control unit).

ABS IN Valve

Switches the fluid pressure line to increase or hold according to signals from control unit.

ABS OUT Valve

COMPONENT PARTS

[VDC/TCS/ABS]

< SYSTEM DESCRIPTION >

Switches the fluid pressure line to increase, hold or decrease according to signals from control unit.

Cut Valve 1, Cut Valve 2

Shuts off the ordinary brake line from master cylinder, when VDC function and TCS function are activated.

Suction Valve 1, Suction Valve 2

Supplies the brake fluid from master cylinder to the pump, when VDC function and TCS function are activated.

Return Check Valve

Returns the brake fluid from brake caliper and wheel cylinder to master cylinder by bypassing orifice of each valve when brake is released.

Reservoir

Temporarily reserves the brake fluid drained from brake caliper, so that pressure efficiently decreases when decreasing pressure of brake caliper and wheel cylinder.

Yaw rate/side/decel G sensor

Calculates the following information that affects the vehicle, and transmits a signal to ABS actuator and electric unit (control unit) via communication lines.

- Vehicle rotation angular velocity (yaw rate signal)
- Vehicle lateral acceleration (side G signal) and longitudinal acceleration (decel G signal)

Pressure Sensor

Detects the brake fluid pressure and transmits signal to ABS actuator and electric unit (control unit).

Wheel Sensor and Sensor Rotor

INFOID:000000007616447

NOTE:

- Wheel sensor of front wheel is installed on steering knuckle.
- Sensor rotor of front wheel is integrated in wheel hub assembly.
- Wheel sensor of rear wheel is installed on back plate of rear brake.
- Sensor rotor of rear wheel is installed on rear brake drum.
- Never measure resistance and voltage value using a tester because sensor is active sensor.
- Downsize and weight reduction is aimed. IC for detection portion and magnet for sensor rotor are adopted.
- Power supply is supplied to detection portion so that magnetic field line is read. Magnetic field that is detected is converted to current signal.
- When sensor rotor rotates, magnetic field changes. Magnetic field change is converted to current signals (rectangular wave) and is transmitted to ABS actuator and electric unit (control unit). Change of magnetic field is proportional to wheel speed.

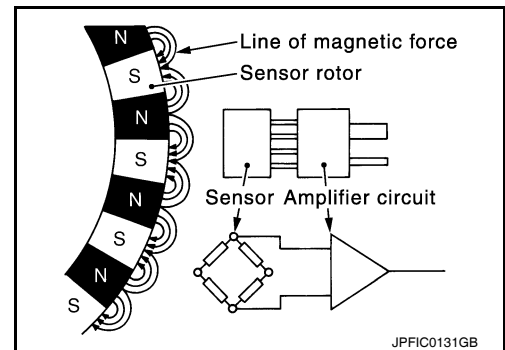

Stop Lamp Switch

INFOID:000000007616448

Detects the operation status of brake pedal and transmits converted electric signal to ABS actuator and electric unit (control unit).

Steering Angle Sensor

INFOID:000000007616449

Detects the following information and transmits steering angle signal to ABS actuator and electric unit (control unit) via CAN communication.

- Steering wheel rotation amount
- Steering wheel rotation angular velocity
- Steering wheel rotation direction

VDC OFF Switch

INFOID:000000007616450

- Non-operational status or standby status of VDC and TCS functions can be selected using VDC OFF switch. VDC OFF indicator lamp indicates the operation status of function. (ON: Non-operational status, OFF: Standby status)
- VDC OFF indicator lamp turns OFF (standby status) when the engine is started again after it is stopped once while VDC OFF indicator lamp is ON (non-operational status).

COMPONENT PARTS

< SYSTEM DESCRIPTION >

[VDC/TCS/ABS]

Brake Fluid Level Switch

INFOID:000000007616451

Detects the brake fluid level in reservoir tank and transmits converted electric signal from combination meter to ABS actuator and electric unit (control unit) via CAN communication.

A

Parking Brake Switch

INFOID:000000007616452

Detects the operation status of parking brake switch and transmits converted electric signal from combination meter to ABS actuator and electric unit (control unit) via CAN communication.

B

C

D

E

BRC

G

H

I

J

K

L

M

N

O

P

SYSTEM

VDC/TCS/ABS

VDC/TCS/ABS : System Diagram

INFOID:000000007630848

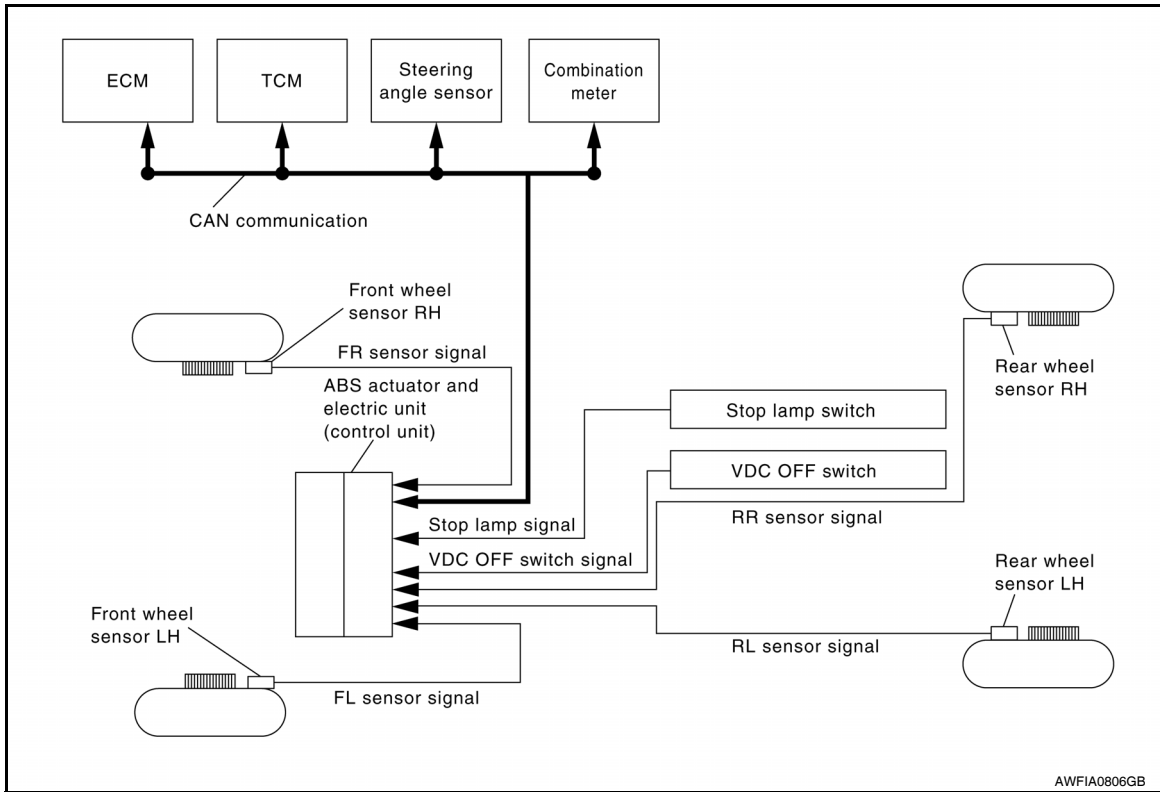

VDC/TCS/ABS : System Description

INFOID:000000007616454

- The system switches fluid pressure of each brake caliper and each wheel cylinder to increase, to hold, or to decrease according to signals from control unit in ABS actuator and electric unit (control unit). This control system is applied to VDC, TCS, ABS and EBD functions.
- Fail-safe function is available for each function and is activated by each function when system malfunction occurs.

INPUT SIGNAL AND OUTPUT SIGNAL

Major signal transmission between each unit via communication lines is shown in the following table.

SYSTEM

< SYSTEM DESCRIPTION >

[VDC/TCS/ABS]

| Component | Signal description |
|-----------------------|---|
| Steering angle sensor | Transmits the steering angle sensor signal to ABS actuator and electric unit (control unit) via CAN communication. |
| ECM | Transmits the following signals to ABS actuator and electric unit (control unit) via CAN communication. <ul style="list-style-type: none"> • Accelerator pedal position signal • Engine speed signal • Target throttle position signal |
| TCM | Transmits the current gear position signal to ABS actuator and electric unit (control unit) via CAN communication. |
| Combination meter | Transmits the following signals to ABS actuator and electric unit (control unit) via CAN communication. <ul style="list-style-type: none"> • Brake fluid level switch signal • Parking brake switch signal Receives the following signals from ABS actuator and electric unit (control unit) via CAN communication. <ul style="list-style-type: none"> • ABS warning lamp signal • Brake warning lamp signal • VDC OFF indicator lamp signal • SLIP indicator lamp signal |

VALVE OPERATION (VDC AND TCS FUNCTIONS)

The control unit built in the ABS actuator and electric unit (control unit) controls fluid pressure of the brake calipers by operating each valve.

VDC and TCS Functions are Operating (Pressure Increases)

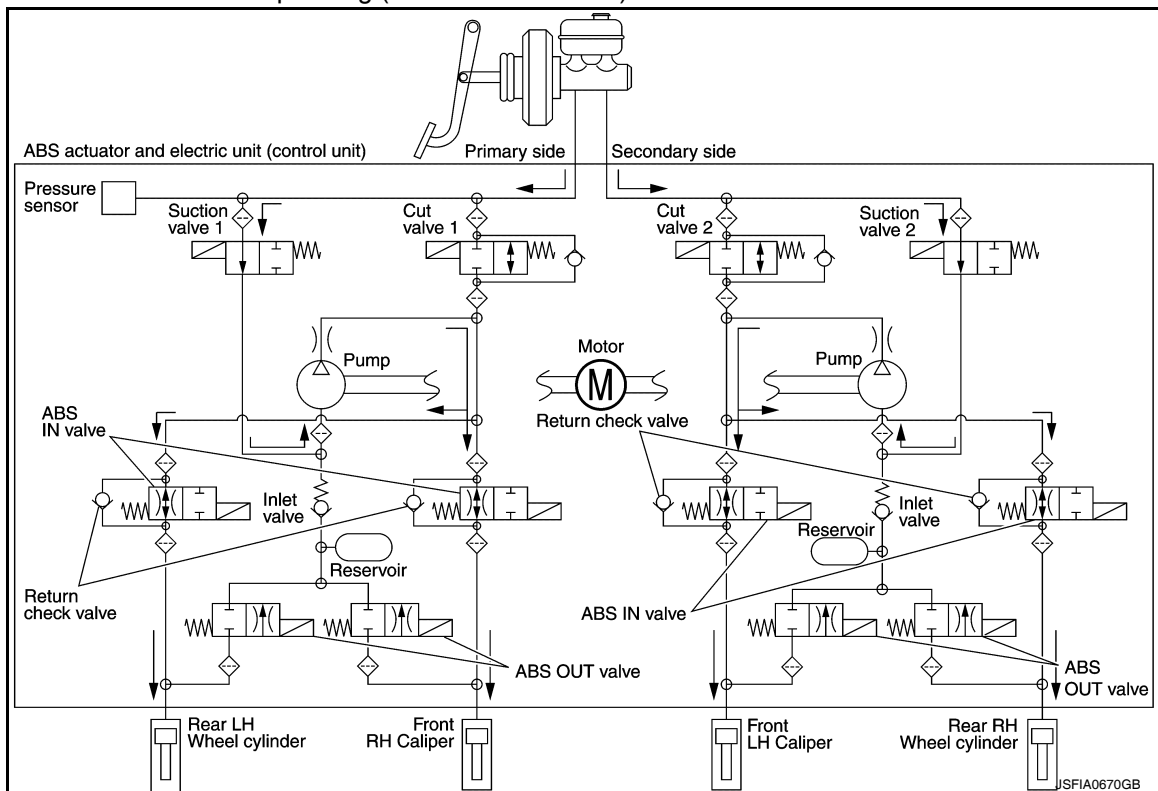

| Name | Not activated | Pressure increases |
|-----------------|--------------------------------------|-------------------------------------|
| Cut valve 1 | Power supply is not supplied (open) | Power supply is supplied (close) |
| Cut valve 2 | Power supply is not supplied (open) | Power supply is supplied (close) |
| Suction valve 1 | Power supply is not supplied (close) | Power supply is supplied (open) |
| Suction valve 2 | Power supply is not supplied (close) | Power supply is supplied (open) |
| ABS IN valve | Power supply is not supplied (open) | Power supply is not supplied (open) |

SYSTEM

< SYSTEM DESCRIPTION >

[VDC/TCS/ABS]

| Name | Not activated | Pressure increases |
|---|--------------------------------------|--------------------------------------|
| ABS OUT valve | Power supply is not supplied (close) | Power supply is not supplied (close) |
| Each brake caliper and each wheel cylinder (fluid pressure) | — | Pressure increases |

Front RH brake caliper

- Brake fluid is conveyed to the pump from the master cylinder through suction valve 1 and is pressurized by the pump operation. The pressurized brake fluid is supplied to the front RH brake caliper through the ABS IN valve. For the left caliper, brake fluid pressure is maintained because the pressurization is unnecessary. The pressurization for the left caliper is controlled separately from the right caliper.

Front LH brake caliper

- Brake fluid is conveyed to the pump from the master cylinder through suction valve 2 and is pressurized by the pump operation. The pressurized brake fluid is supplied to the front LH brake caliper through the ABS IN valve. For the right caliper, brake fluid pressure is maintained because the pressurization is unnecessary. The pressurization for the right caliper is controlled separately from the left caliper.

Rear RH wheel cylinder

- Brake fluid is conveyed to the pump from the master cylinder through suction valve 2 and is pressurized by the pump operation. The pressurized brake fluid is supplied to the rear RH wheel cylinder through the ABS IN valve. For the left wheel cylinder, brake fluid pressure is maintained because the pressurization is unnecessary. The pressurization for the left wheel cylinder is controlled separately from the right wheel cylinder.

Rear LH wheel cylinder

- Brake fluid is conveyed to the pump from the master cylinder through suction valve 1 and is pressurized by the pump operation. The pressurized brake fluid is supplied to the rear LH wheel cylinder through the ABS IN valve. For the right wheel cylinder, brake fluid pressure is maintained because the pressurization is unnecessary. The pressurization for the right wheel cylinder is controlled separately from the left wheel cylinder.

VDC and TCS Functions Start Operating (Pressure Holds)

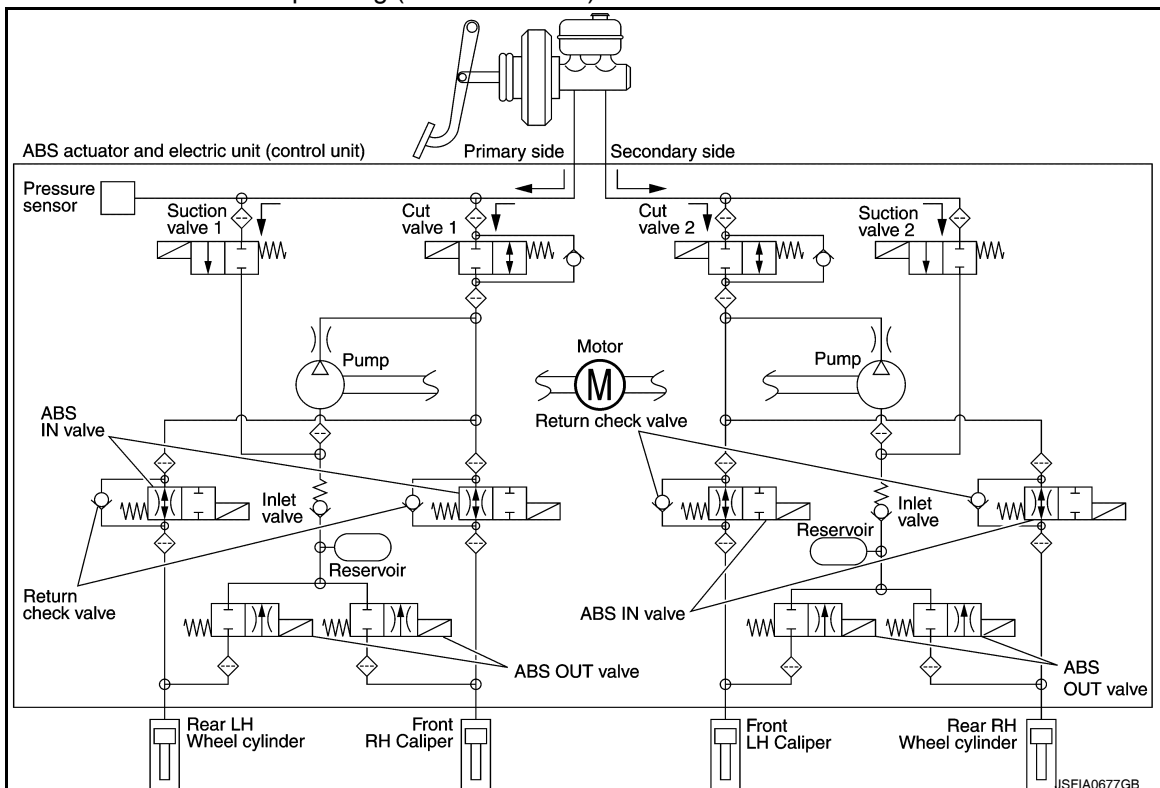

SYSTEM

< SYSTEM DESCRIPTION >

[VDC/TCS/ABS]

| Name | Not activated | Pressure holds |
|--|--------------------------------------|--------------------------------------|
| Cut valve 1 | Power supply is not supplied (open) | Power supply is supplied (close) |
| Cut valve 2 | Power supply is not supplied (open) | Power supply is supplied (close) |
| Suction valve 1 | Power supply is not supplied (close) | Power supply is not supplied (close) |
| Suction valve 2 | Power supply is not supplied (close) | Power supply is not supplied (close) |
| ABS IN valve | Power supply is not supplied (open) | Power supply is not supplied (open) |
| ABS OUT valve | Power supply is not supplied (close) | Power supply is not supplied (close) |
| Each brake caliper and wheel cylinder (fluid pressure) | — | Pressure holds |

Front RH brake caliper

- Since the cut valve 1 and the suction valve 1 are closed, the front RH brake caliper, master cylinder, and reservoir are blocked. This maintains fluid pressure applied on the front RH brake caliper. The pressurization for the left caliper is controlled separately from the right caliper.

Front LH brake caliper

- Since the cut valve 2 and the suction valve 2 are closed, the front LH brake caliper, master cylinder, and reservoir are blocked. This maintains fluid pressure applied on the front LH brake caliper. The pressurization for the right caliper is controlled separately from the left caliper.

Rear RH wheel cylinder

- Since the cut valve 2 and the suction valve 2 are closed, the rear RH wheel cylinder, master cylinder, and reservoir are blocked. This maintains fluid pressure applied on the rear RH wheel cylinder. The pressurization for the left wheel cylinder is controlled separately from the right wheel cylinder.

Rear LH wheel cylinder

- Since the cut valve 1 and the suction valve 1 are closed, the rear LH wheel cylinder, master cylinder, and reservoir are blocked. This maintains fluid pressure applied on the rear LH wheel cylinder. The pressurization for the right wheel cylinder is controlled separately from the left wheel cylinder.

VDC and TCS Functions Operating (Pressure Decreases)

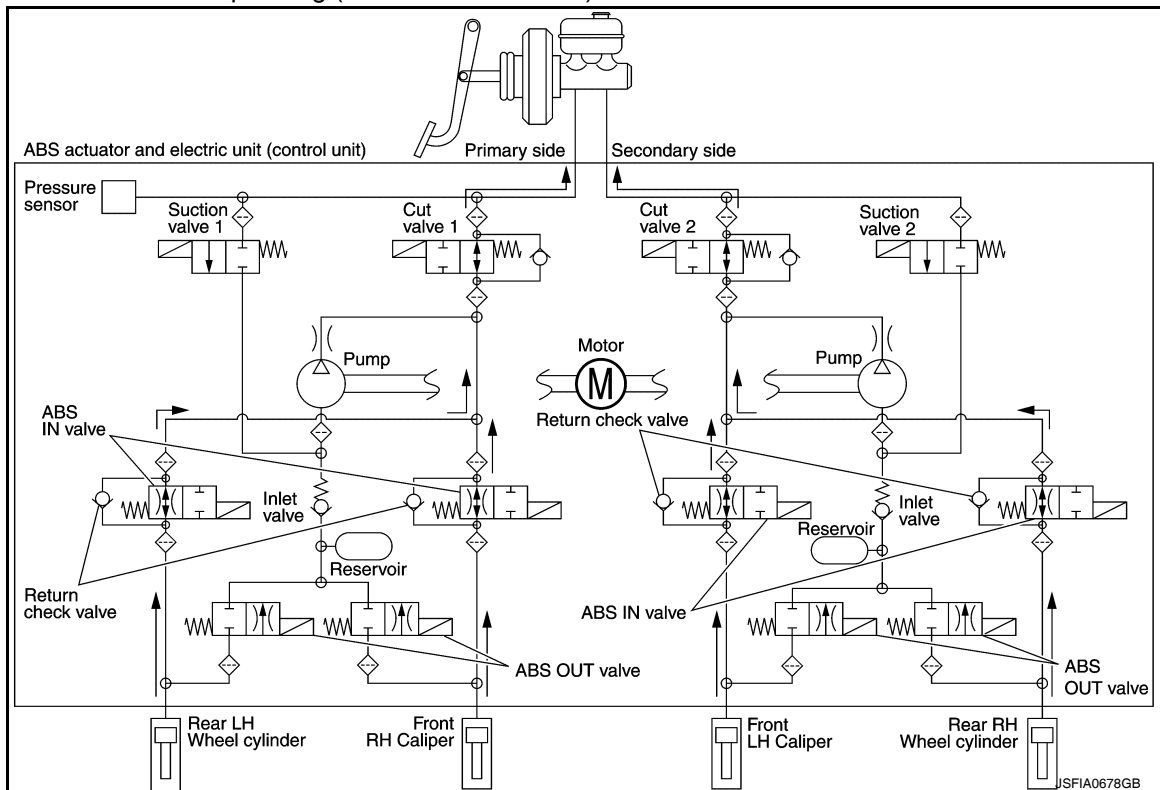

SYSTEM

< SYSTEM DESCRIPTION >

[VDC/TCS/ABS]

| Name | Not activated | During pressure decreases |
|---|--------------------------------------|--------------------------------------|
| Cut valve 1 | Power supply is not supplied (open) | Power supply is not supplied (open) |
| Cut valve 2 | Power supply is not supplied (open) | Power supply is not supplied (open) |
| Suction valve 1 | Power supply is not supplied (close) | Power supply is not supplied (close) |
| Suction valve 2 | Power supply is not supplied (close) | Power supply is not supplied (close) |
| ABS IN valve | Power supply is not supplied (open) | Power supply is not supplied (open) |
| ABS OUT valve | Power supply is not supplied (close) | Power supply is not supplied (close) |
| Each brake caliper and each wheel cylinder (fluid pressure) | — | Pressure decreases |

Front RH brake caliper

- Since the suction valve 1 and the ABS OUT valve are closed and the cut valve 1 and the ABS IN valve are open, the fluid pressure applied on the front RH brake caliper is reduced by supplying the fluid pressure to the master cylinder via the ABS IN valve and the cut valve 1. The pressurization for the right caliper is controlled separately from the left caliper.

Front LH brake caliper

- Since the suction valve 2 and the ABS OUT valve are closed and the cut valve 2 and the ABS IN valve are open, the fluid pressure applied on the front LH brake caliper is reduced by supplying the fluid pressure to the master cylinder via the ABS IN valve and the cut valve 2. The pressurization for the left caliper is controlled separately from the right caliper.

Rear RH wheel cylinder

- Since the suction valve 2 and the ABS OUT valve are closed and the cut valve 2 and the ABS IN valve are open, the fluid pressure applied on the rear RH wheel cylinder is reduced by supplying the fluid pressure to the master cylinder via the ABS IN valve and the cut valve 2. The pressurization for the right wheel cylinder is controlled separately from the left wheel cylinder.

Rear LH wheel cylinder

- Since the suction valve 1 and the ABS OUT valve are closed and the cut valve 1 and the ABS IN valve are open, the fluid pressure applied on the rear LH wheel cylinder is reduced by supplying the fluid pressure to the master cylinder via the ABS IN valve and the cut valve 1. The pressurization for the left wheel cylinder is controlled separately from the right wheel cylinder.

Component Parts and Function

| Component | Function |
|------------------------------------|---|
| Pump | Returns the brake fluid reserved in reservoir to master cylinder by reducing pressure. |
| Motor | Activates the pump according to signals from ABS actuator and electric unit (control unit). |
| Cut valve 1 Cut valve 2 | Shuts off the ordinary brake line from master cylinder. |
| Suction valve 1 Suction valve 2 | Supplies the brake fluid from master cylinder to the pump. |
| ABS IN valve | Switches the fluid pressure line to increase or hold according to signals from control unit. |
| ABS OUT valve | Switches the fluid pressure line to increase, hold or decrease according to signals from control unit. |
| Return check valve | Returns the brake fluid from brake caliper and wheel cylinder to master cylinder by bypassing orifice of each valve when brake is released. |
| Reservoir | Temporarily reserves the brake fluid drained from brake caliper, so that pressure efficiently decreases when decreasing pressure of brake caliper and wheel cylinder. |
| Pressure sensor | Detects the brake fluid pressure and transmits signal to ABS actuator and electric unit (control unit). |

VALVE OPERATION (ABS AND EBD FUNCTIONS)

The control unit built into the ABS actuator and electric unit (control unit) controls fluid pressure of the brake calipers by operating each valve.

SYSTEM

< SYSTEM DESCRIPTION >

[VDC/TCS/ABS]

Brake Pedal Applied or ABS Function Operating (Pressure Increases)

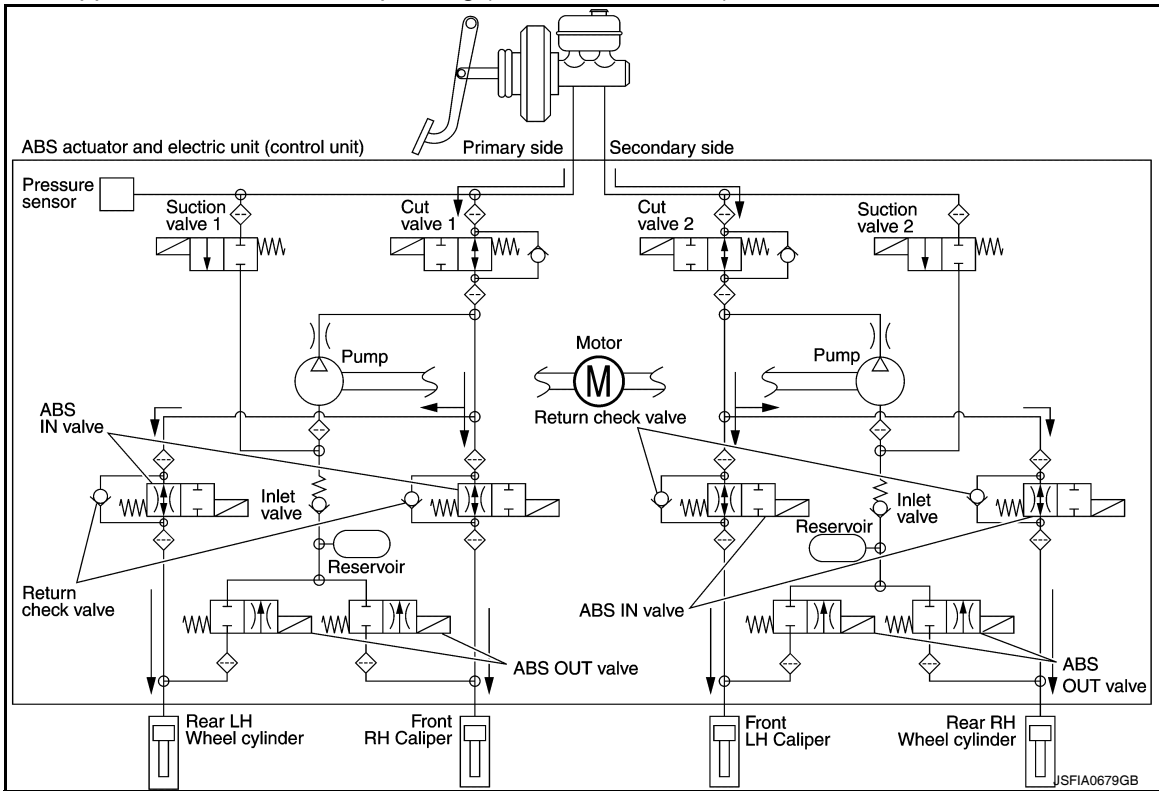

| Name | Not activated | During pressure increases |
|---|--------------------------------------|--------------------------------------|
| Cut valve 1 | Power supply is not supplied (open) | Power supply is not supplied (open) |
| Cut valve 2 | Power supply is not supplied (open) | Power supply is not supplied (open) |
| Suction valve 1 | Power supply is not supplied (close) | Power supply is not supplied (close) |
| Suction valve 2 | Power supply is not supplied (close) | Power supply is not supplied (close) |
| ABS IN valve | Power supply is not supplied (open) | Power supply is not supplied (open) |
| ABS OUT valve | Power supply is not supplied (close) | Power supply is not supplied (close) |
| Each brake caliper and each wheel cylinder (fluid pressure) | — | Pressure increases |

Front RH brake caliper

- When the cut valve 1 and the ABS IN valve opens, brake fluid is supplied to the front RH brake caliper from the master cylinder through the ABS IN valve. Brake fluid does not flow into the reservoir because the ABS OUT valve is closed.

Front LH brake caliper

- When the cut valve 2 and the ABS IN valve opens, brake fluid is supplied to the front LH brake caliper from the master cylinder through the ABS IN valve. Brake fluid does not flow into the reservoir because the ABS OUT valve is closed.

Rear RH wheel cylinder

- When the cut valve 2 and the ABS IN valve opens, brake fluid is supplied to the rear RH wheel cylinder from the master cylinder through the ABS IN valve. Brake fluid does not flow into the reservoir because the ABS OUT valve is closed.

Rear LH wheel cylinder

- When the cut valve 1 and the ABS IN valve opens, brake fluid is supplied to the rear LH wheel cylinder from the master cylinder through the ABS IN valve. Brake fluid does not flow into the reservoir because the ABS OUT valve is closed.

SYSTEM

< SYSTEM DESCRIPTION >

[VDC/TCS/ABS]

ABS Function Starts Operating (Pressure Holds)

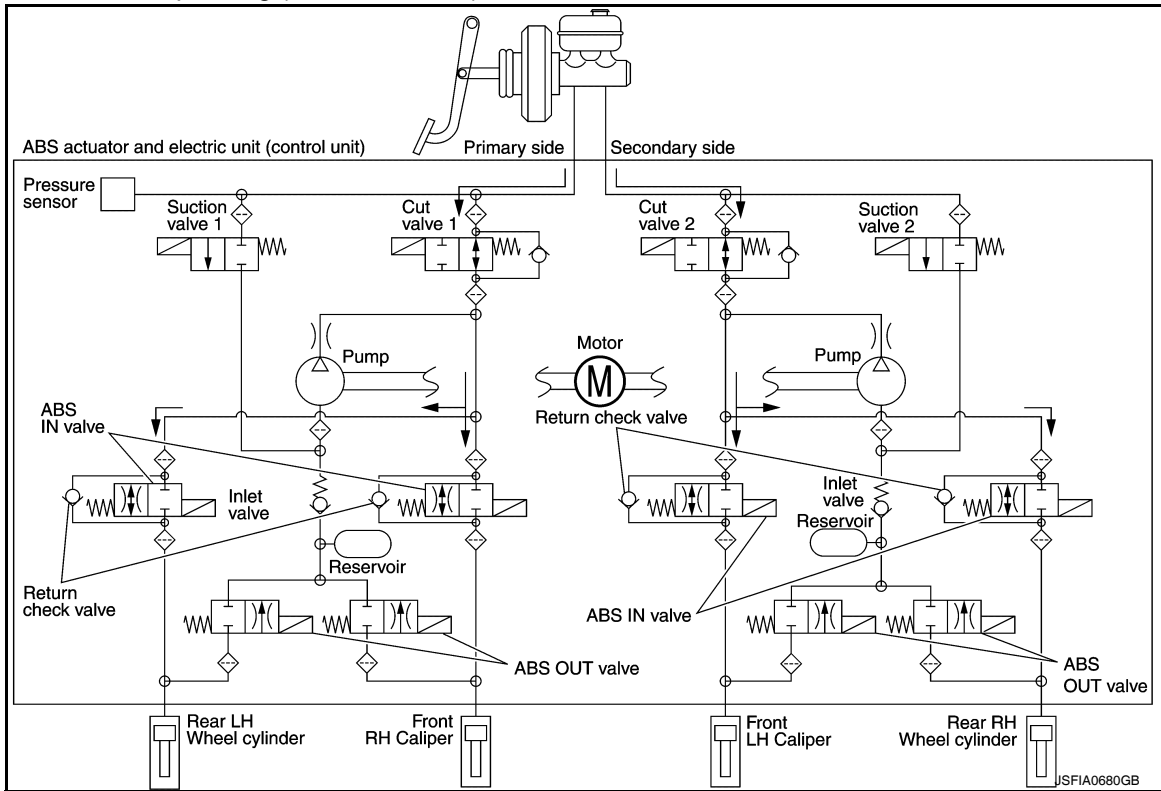

| Name | Not activated | During pressure holds |
|---|--------------------------------------|--------------------------------------|
| Cut valve 1 | Power supply is not supplied (open) | Power supply is not supplied (open) |
| Cut valve 2 | Power supply is not supplied (open) | Power supply is not supplied (open) |
| Suction valve 1 | Power supply is not supplied (close) | Power supply is not supplied (close) |
| Suction valve 2 | Power supply is not supplied (close) | Power supply is not supplied (close) |
| ABS IN valve | Power supply is not supplied (open) | Power supply is supplied (close) |
| ABS OUT valve | Power supply is not supplied (close) | Power supply is not supplied (close) |
| Each brake caliper and each wheel cylinder (fluid pressure) | — | Pressure holds |

Front RH brake caliper

- Since the ABS IN valve and the ABS OUT valve are closed, the front RH brake caliper, master cylinder, and reservoir are blocked. This maintains fluid pressure applied on the front RH brake caliper.

Front LH brake caliper

- Since the ABS IN valve and the ABS OUT valve are closed, the front LH brake caliper, master cylinder, and reservoir are blocked. This maintains fluid pressure applied on the front LH brake caliper.

Rear RH wheel cylinder

- Since the ABS IN valve and the ABS OUT valve are closed, the rear RH wheel cylinder, master cylinder, and reservoir are blocked. This maintains fluid pressure applied on the rear RH wheel cylinder.

Rear LH wheel cylinder

- Since the ABS IN valve and the ABS OUT valve are closed, the rear LH wheel cylinder, master cylinder, and reservoir are blocked. This maintains fluid pressure applied on the rear LH wheel cylinder.

SYSTEM

< SYSTEM DESCRIPTION >

[VDC/TCS/ABS]

ABS Function Operating (Pressure Decreases)

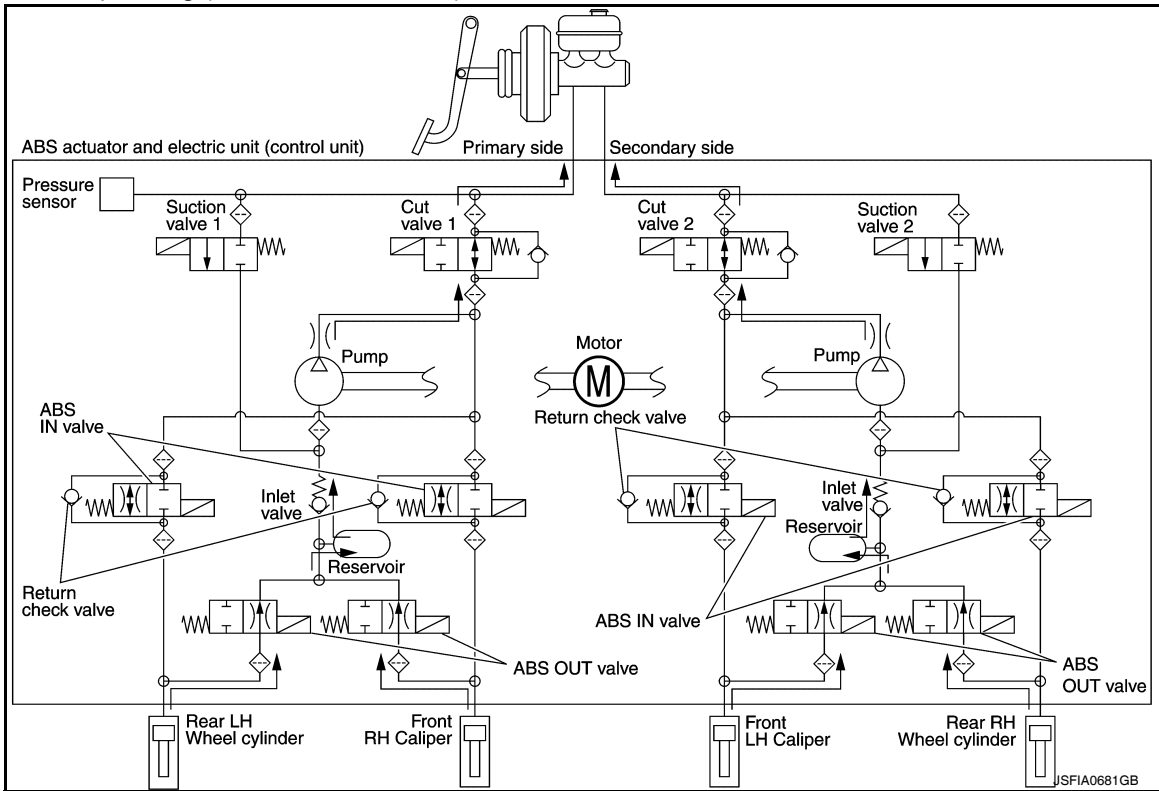

| Name | Not activated | During pressure decreases |
|---|--------------------------------------|--------------------------------------|
| Cut valve 1 | Power supply is not supplied (open) | Power supply is not supplied (open) |
| Cut valve 2 | Power supply is not supplied (open) | Power supply is not supplied (open) |
| Suction valve 1 | Power supply is not supplied (close) | Power supply is not supplied (close) |
| Suction valve 2 | Power supply is not supplied (close) | Power supply is not supplied (close) |
| ABS IN valve | Power supply is not supplied (open) | Power supply is supplied (close) |
| ABS OUT valve | Power supply is not supplied (close) | Power supply is supplied (open) |
| Each brake caliper and each wheel cylinder (fluid pressure) | — | Pressure decreases |

Front RH brake caliper

- Since the ABS IN valve is closed and the ABS OUT valve is opened, fluid pressure applied on the front RH brake caliper is supplied to the reservoir through the ABS OUT valve. This fluid pressure decreases when sent to the master cylinder by the pump.

Front LH brake caliper

- Since the ABS IN valve is closed and the ABS OUT valve is opened, fluid pressure applied on the front LH brake caliper is supplied to the reservoir through the ABS OUT valve. This fluid pressure decreases when sent to the master cylinder by the pump.

Rear RH wheel cylinder

- Since the ABS IN valve is closed and the ABS OUT valve is opened, fluid pressure applied on the rear RH wheel cylinder is supplied to the reservoir through the ABS OUT valve. This fluid pressure decreases when sent to the master cylinder by the pump.

Rear LH wheel cylinder

- Since the ABS IN valve is closed and the ABS OUT valve is opened, fluid pressure applied on the rear LH wheel cylinder is supplied to the reservoir through the ABS OUT valve. This fluid pressure decreases when sent to the master cylinder by the pump.

SYSTEM

< SYSTEM DESCRIPTION >

[VDC/TCS/ABS]

ABS Function Operating (Pressure Increases)

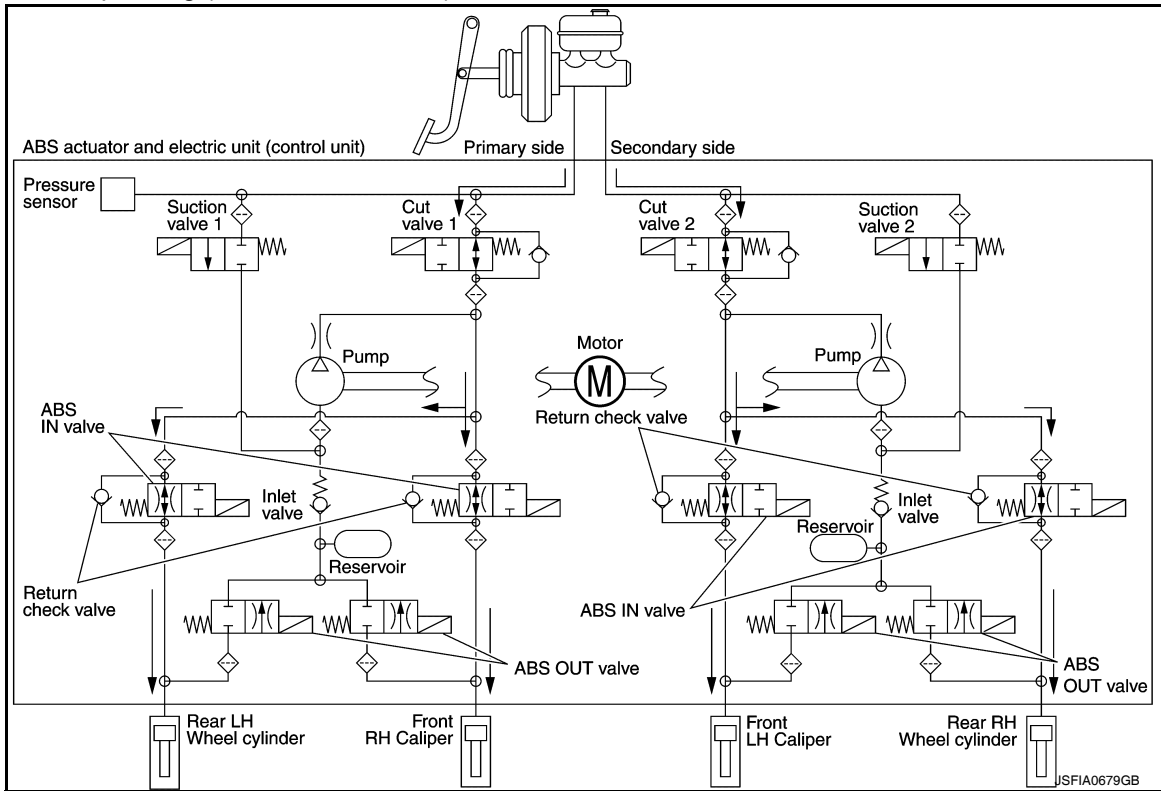

| Name | Not activated | During pressure increases |
|---|--------------------------------------|--------------------------------------|
| Cut valve 1 | Power supply is not supplied (open) | Power supply is not supplied (open) |
| Cut valve 2 | Power supply is not supplied (open) | Power supply is not supplied (open) |
| Suction valve 1 | Power supply is not supplied (close) | Power supply is not supplied (close) |
| Suction valve 2 | Power supply is not supplied (close) | Power supply is not supplied (close) |
| ABS IN valve | Power supply is not supplied (open) | Power supply is not supplied (open) |
| ABS OUT valve | Power supply is not supplied (close) | Power supply is not supplied (close) |
| Each brake caliper and each wheel cylinder (fluid pressure) | — | Pressure increases |

Front RH brake caliper

- Brake fluid is supplied to the front RH brake caliper from the master cylinder through the cut valve 1 and the ABS IN valve. Since the suction valve 1 and the ABS OUT valve is closed, the fluid does not flow into the reservoir. The amount of brake fluid supplied to the front RH brake caliper from the master cylinder is controlled according to time that the ABS IN valve is not energized (time that the ABS IN valve is open).

Front LH brake caliper

- Brake fluid is supplied to the front LH brake caliper from the master cylinder through the cut valve 2 and the ABS IN valve. Since the suction valve 2 and the ABS OUT valve is closed, the fluid does not flow into the reservoir. The amount of brake fluid supplied to the front LH brake caliper from the master cylinder is controlled according to time that the ABS IN valve is not energized (time that the ABS IN valve is open).

Rear RH wheel cylinder

- Brake fluid is supplied to the rear RH wheel cylinder from the master cylinder through the cut valve 2 and the ABS IN valve. Since the suction valve 2 and the ABS OUT valve is closed, the fluid does not flow into the reservoir. The amount of brake fluid supplied to the rear RH wheel cylinder from the master cylinder is controlled according to time that the ABS IN valve is not energized (time that the ABS IN valve is open).

Rear LH wheel cylinder

- Brake fluid is supplied to the rear LH wheel cylinder from the master cylinder through the cut valve 1 and the ABS IN valve. Since the suction valve 1 and the ABS OUT valve is closed, the fluid does not flow into the

SYSTEM

< SYSTEM DESCRIPTION >

[VDC/TCS/ABS]

reservoir. The amount of brake fluid supplied to the rear LH wheel cylinder from the master cylinder is controlled according to time that the ABS IN valve is not energized (time that the ABS IN valve is open).

Brake Release

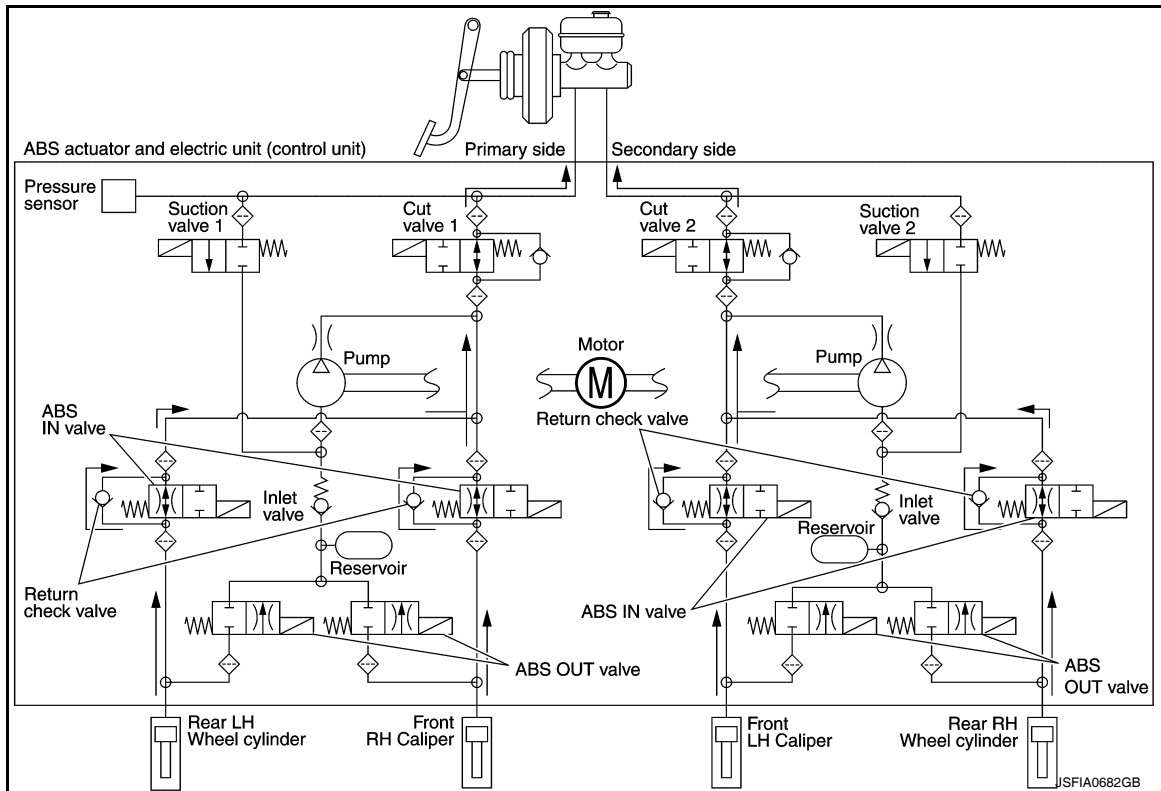

| Name | Not activated | During brake release |
|---|--------------------------------------|--------------------------------------|
| Cut valve 1 | Power supply is not supplied (open) | Power supply is not supplied (open) |
| Cut valve 2 | Power supply is not supplied (open) | Power supply is not supplied (open) |
| Suction valve 1 | Power supply is not supplied (close) | Power supply is not supplied (close) |
| Suction valve 2 | Power supply is not supplied (close) | Power supply is not supplied (close) |
| ABS IN valve | Power supply is not supplied (open) | Power supply is not supplied (open) |
| ABS OUT valve | Power supply is not supplied (close) | Power supply is not supplied (close) |
| Each brake caliper and each wheel cylinder (fluid pressure) | — | Pressure decreases |

Front RH brake caliper

- Brake fluid is supplied to the front RH brake caliper through the return check valve of the ABS IN valve and the cut valve 1, and returns to the master cylinder.

Front LH brake caliper

- Brake fluid is supplied to the front LH brake caliper through the return check valve of the ABS IN valve and the cut valve 2, and returns to the master cylinder.

Rear RH wheel cylinder

- Brake fluid is supplied to the rear RH wheel cylinder through the return check valve of the ABS IN valve and the cut valve 2, and returns to the master cylinder.

Rear LH wheel cylinder

- Brake fluid is supplied to the rear LH wheel cylinder through the return check valve of the ABS IN valve and the cut valve 1, and returns to the master cylinder.

Component Parts and Function

SYSTEM

< SYSTEM DESCRIPTION >

[VDC/TCS/ABS]

| Component | Function |
|------------------------------------|---|
| Pump | Returns the brake fluid reserved in reservoir to master cylinder by reducing pressure. |
| Motor | Activates the pump according to signals from ABS actuator and electric unit (control unit). |
| Cut valve 1 Cut valve 2 | Shuts off the ordinary brake line from master cylinder. |
| Suction valve 1 Suction valve 2 | Supplies the brake fluid from master cylinder to the pump. |
| ABS IN valve | Switches the fluid pressure line to increase or hold according to signals from control unit. |
| ABS OUT valve | Switches the fluid pressure line to increase, hold or decrease according to signals from control unit. |
| Return check valve | Returns the brake fluid from brake caliper and wheel cylinder to master cylinder by bypassing orifice of each valve when brake is released. |
| Reservoir | Temporarily reserves the brake fluid drained from brake caliper, so that pressure efficiently decreases when decreasing pressure of brake caliper and wheel cylinder. |
| Pressure sensor | Detects the brake fluid pressure and transmits signal to ABS actuator and electric unit (control unit). |

CONDITIONS FOR INDICATOR LAMP ILLUMINATION

- Turns ON when VDC and TCS functions are switched to non-operational status (OFF) by VDC OFF switch.
- Turns ON when ignition switch turns ON and turns OFF when the system is normal, for bulb check purposes.

| Condition (status) | VDC OFF indicator lamp | SLIP indicator lamp |
|--|------------------------|---------------------|
| Ignition switch OFF | OFF | OFF |
| For approx. 1 second after the ignition switch is turned ON | ON | ON |
| Approx. 1 second after ignition switch is turned ON (when the system is in normal operation) | OFF | OFF |
| When VDC OFF switch is ON (VDC function and TCS function are OFF) | ON | OFF |
| VDC function is malfunctioning | OFF | ON |
| TCS function is malfunctioning | OFF | ON |

CONDITIONS FOR WARNING LAMP ILLUMINATION

Turns ON when ignition switch turns ON and turns OFF when the system is normal, for bulb check purposes.

| Condition (status) | ABS warning lamp | Brake warning lamp |
|--|------------------|--------------------|
| Ignition switch OFF | OFF | OFF |
| For approx. 1 second after the ignition switch is turned ON | ON | ON |
| Approx. 1 second after ignition switch is turned ON (when the system is in normal operation) | OFF | OFF |
| After engine starts | OFF | OFF |
| When parking brake operates (parking brake switch ON) | OFF | ON |
| When brake fluid is less than the specified level (brake fluid level switch ON) | OFF | ON |
| VDC function is malfunctioning | OFF | OFF |
| TCS function is malfunctioning | OFF | OFF |
| ABS function is malfunctioning | ON | OFF |
| EBD function is malfunctioning | ON | ON |
| Brake limited slip differential (BLSD) function is malfunctioning | OFF | OFF |

SYSTEM

< SYSTEM DESCRIPTION >

[VDC/TCS/ABS]

| Condition (status) | ABS warning lamp | Brake warning lamp |
|---------------------------|------------------|--------------------|
| VDC function is operating | OFF | OFF |
| TCS function is operating | OFF | OFF |

VDC/TCS/ABS : VDC Function

INFOID:000000007616456

SYSTEM DIAGRAM

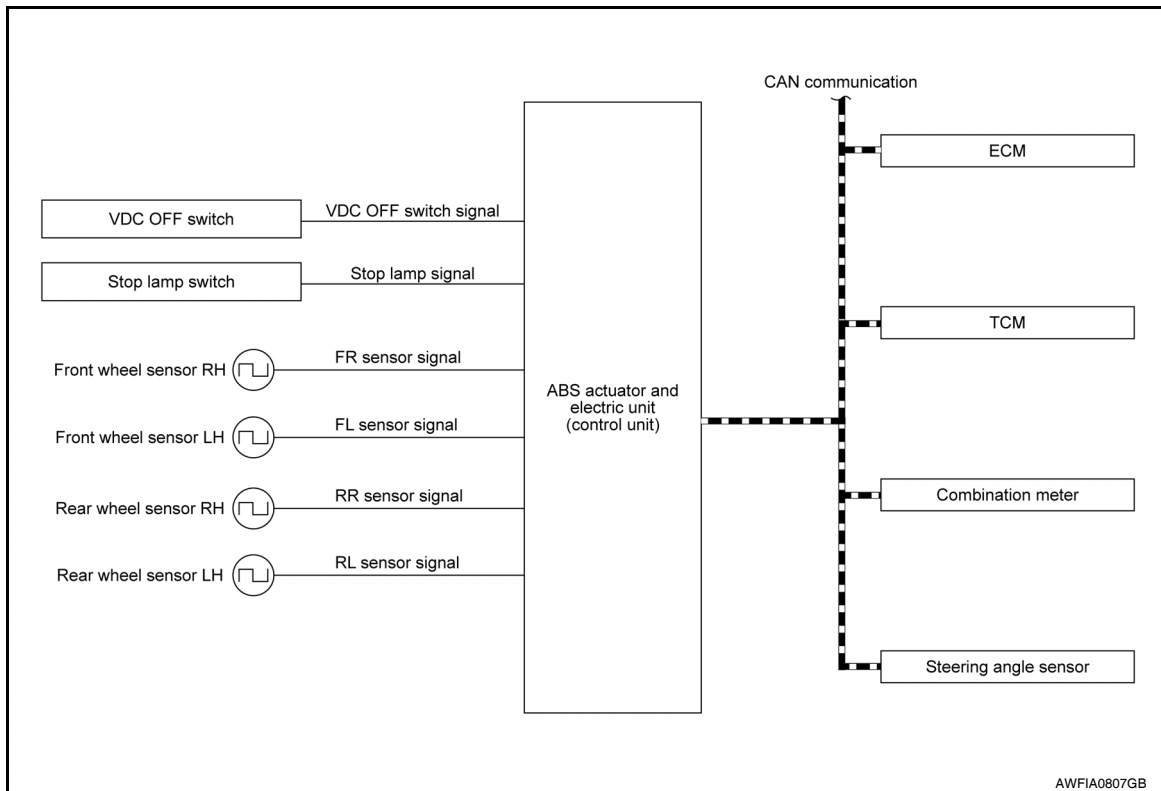

SYSTEM DESCRIPTION

- Side slip or tail slip may occur while driving on a slippery road or intending an urgent evasive driving maneuver. VDC function detects side slip status using each sensor when side slip or tail slip is about to occur and improves vehicle stability by brake control and engine output control during driving.
- In addition to ABS function, EBD function and TCS function, target side slip amount is calculated according to steering operation amount from steering angle sensor. By comparing this information with vehicle side slip amount that is calculated from information from yaw rate/side G sensor and wheel sensor, vehicle driving conditions (conditions of understeer or oversteer) are judged and vehicle stability is improved by brake force control on all 4 wheels and engine output control.

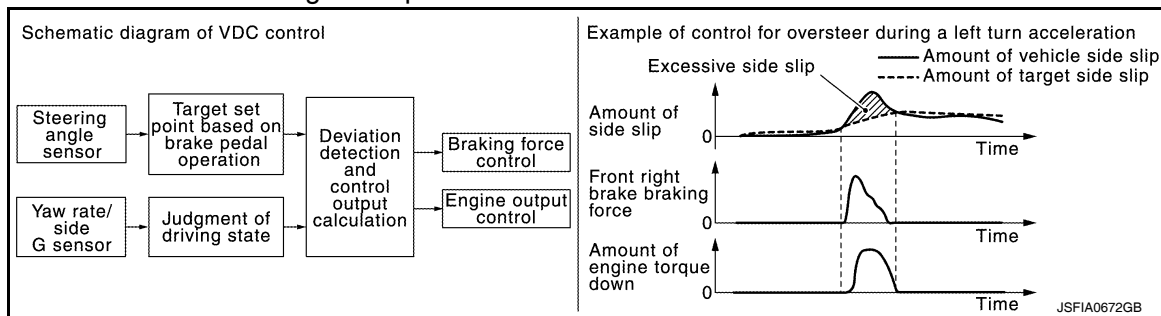

- VDC function can be switched to non-operational status (OFF) by operating VDC OFF switch. In this case, VDC OFF indicator lamp turns ON.
- Control unit portion automatically improves driving stability by performing brake force control as well as engine output control, by transmitting drive signal to actuator portion according to difference between target side slip amount and vehicle side slip amount

SYSTEM

[VDC/TCS/ABS]

< SYSTEM DESCRIPTION >

- Brake force control function at braking hard detects driver's brake operations with the pressure sensor, judges a brake booster's maximum brake power function by using information from the vacuum sensor, and enhances more powerful braking force by controlling brakes of four wheels.
- VDC warning lamp blinks while VDC function is in operation and indicates to the driver that the function is in operation.
- CONSULT can be used to diagnose the system.
- Fail-safe function is adopted. When a malfunction occurs in VDC function, the control is suspended for VDC function and TCS function. However, ABS function and EBD function operate normally. Refer to [BRC-39](#), "Fail-safe".

INPUT SIGNAL AND OUTPUT SIGNAL

Major signal transmission between each unit via communication lines is shown in the following table.

| Component | Signal description |
|-----------------------|---|
| ECM | Transmits the following signals to ABS actuator and electric unit (control unit) via CAN communication. <ul style="list-style-type: none"> • Acceleration pedal position signal • Engine speed signal • Target throttle position signal |
| TCM | Transmits the current gear position signal to ABS actuator and electric unit (control unit) via CAN communication. |
| Steering angle sensor | Transmits the steering angle sensor signal to ABS actuator and electric unit (control unit) via CAN communication. |
| Combination meter | Transmits the following signals to ABS actuator and electric unit (control unit) via CAN communication. <ul style="list-style-type: none"> • Brake fluid level switch signal • parking brake switch signal Receives the following signals from ABS actuator and electric unit (control unit) via CAN communication. <ul style="list-style-type: none"> • VDC OFF indicator lamp signal • SLIP indicator lamp signal |

OPERATION CHARACTERISTICS

VDC Function That Prevents Oversteer Tendency

- During cornering, brake force (brake fluid pressure) is applied on front wheel and rear wheel on the outer side of turn. Momentum is generated directing the vehicle toward the outer side of the turn. Oversteer is prevented.

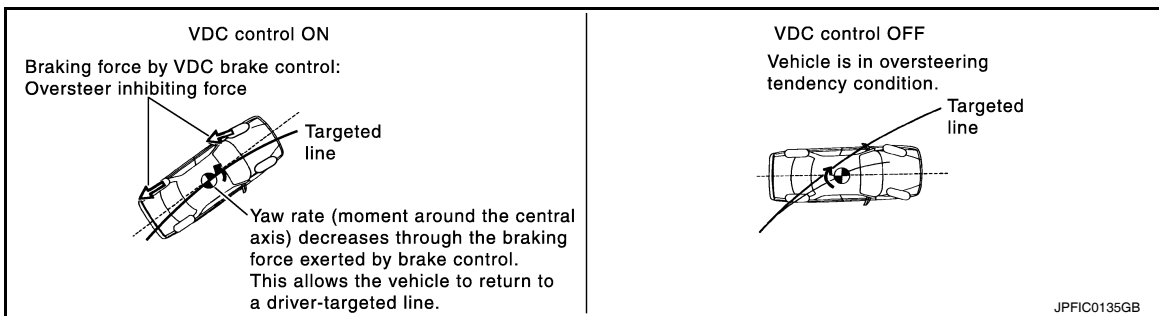

- Changing driving lane on a slippery road, when there may be a tendency to oversteer, engine output is controlled as well as brake force (brake fluid pressure) of 4 wheels. Oversteer tendency decreases.

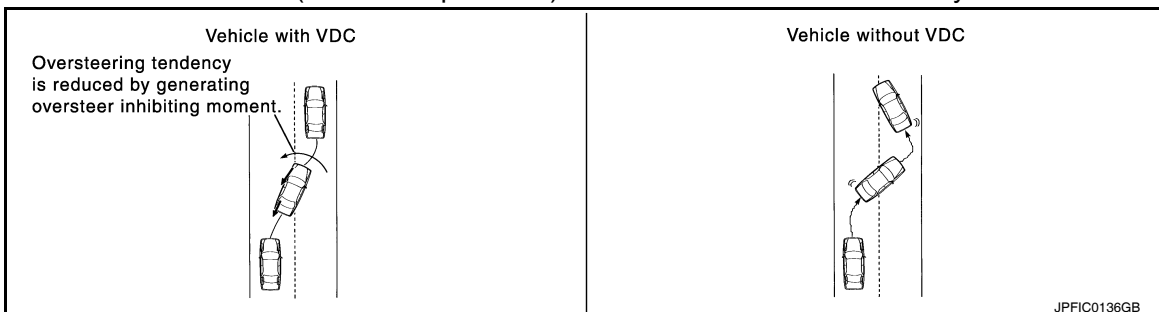

SYSTEM

< SYSTEM DESCRIPTION >

[VDC/TCS/ABS]

VDC Function That Prevents Understeer Tendency

- During cornering, brake force (brake fluid pressure) is applied on front wheel and rear wheel on the inner side of turn. Momentum is generated directing the vehicle toward the inner side of the turn. Understeer is prevented.

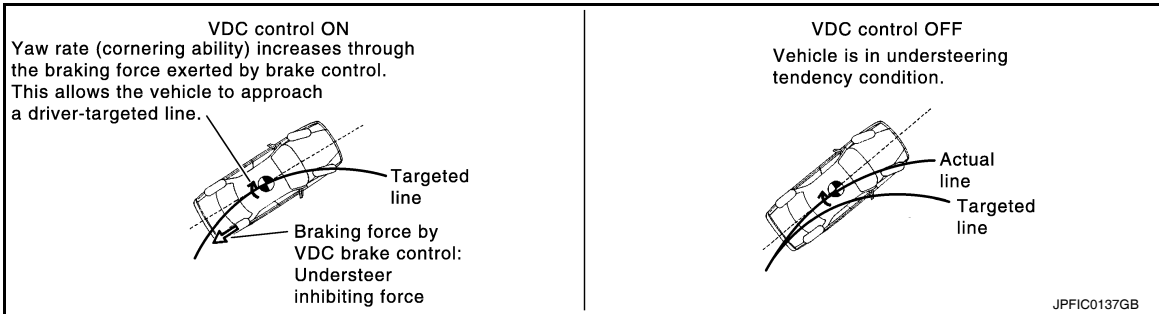

- Applying brakes during cornering on a slippery road, when there may be a tendency to understeer, engine output is controlled as well as brake force (brake fluid pressure) of 4 wheels. Understeer tendency decreases.

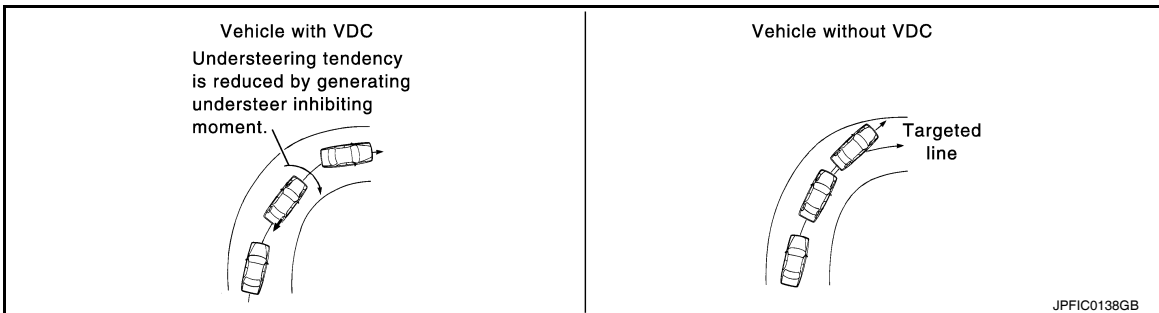

VDC/TCS/ABS : TCS Function

INFOID:000000007616457

SYSTEM DIAGRAM

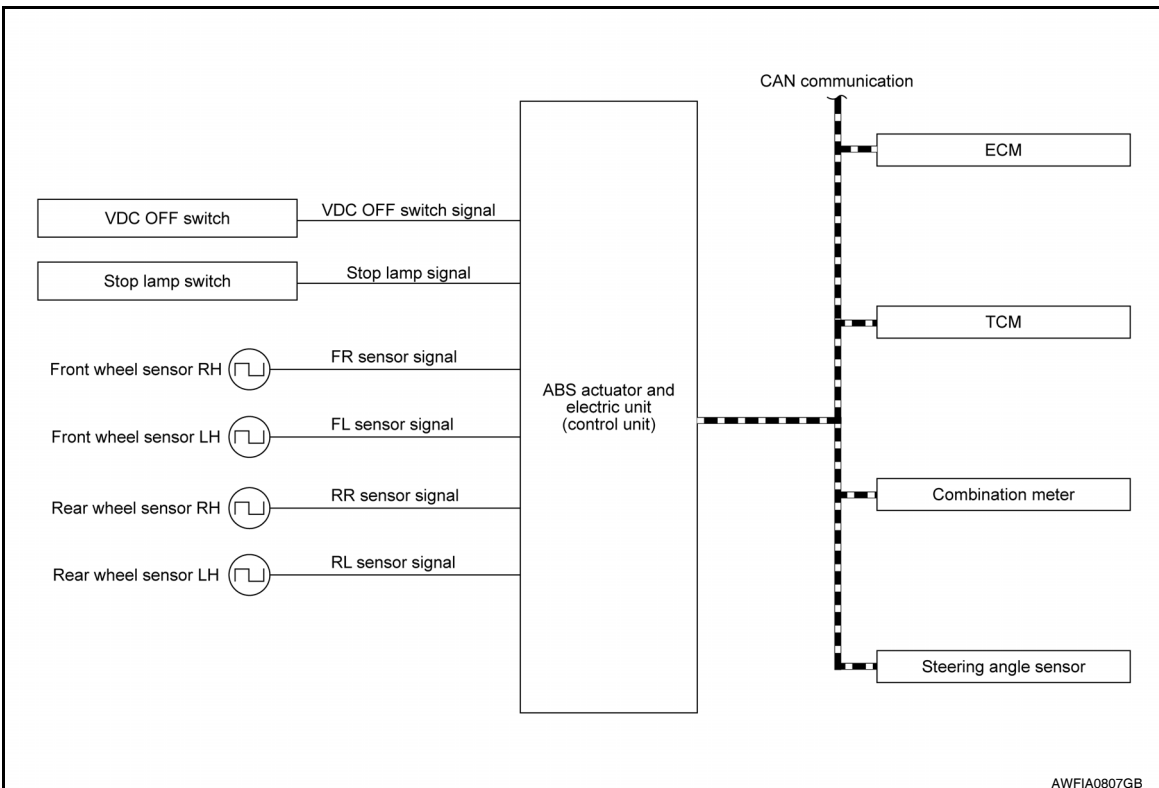

SYSTEM DESCRIPTION

A
B
C
D
E
BRC
G
H
I
J
K
L
M
N
O
P

SYSTEM

[VDC/TCS/ABS]

< SYSTEM DESCRIPTION >

- Wheel spin status of drive wheel is detected by wheel sensor of 4 wheels. Engine output and transmission shift status is controlled so that slip rate of drive wheels is in appropriate level. When wheel spin occurs on drive wheel, ABS actuator and electric unit (control unit) perform brake force control of LH and RH drive wheels (apply brake force by increasing brake fluid pressure of drive wheel) and decrease engine torque by engine torque control. Wheel spin amount decreases. Engine torque is controlled to appropriate level.
- TCS function can be switched to non-operational status (OFF) by operating VDC OFF switch. In this case, VDC OFF indicator lamp turns ON.
- SLIP indicator lamp blinks while TCS function is in operation and indicates to the driver that the function is in operation.
- CONSULT can be used to diagnose the system.
- Fail-safe function is adopted. When a malfunction occurs in TCS function, the control is suspended for VDC function and TCS function. However, ABS function and EBD function operate normally. Refer to [BRC-39. "Fail-safe"](#).

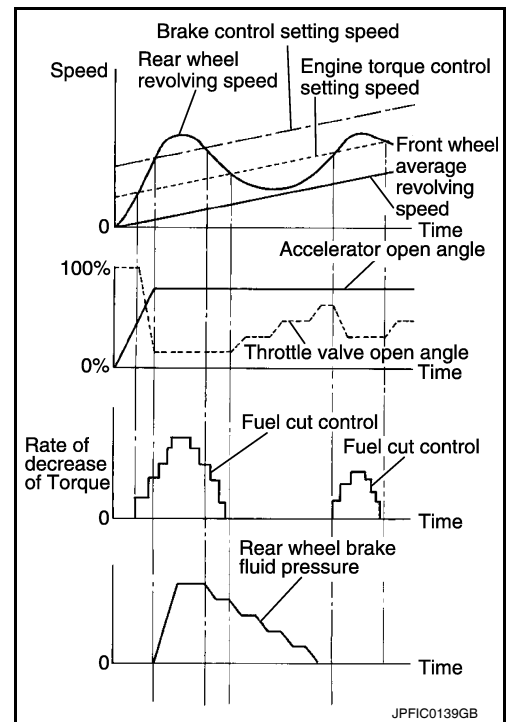

INPUT SIGNAL AND OUTPUT SIGNAL

Major signal transmission between each unit via communication lines is shown in the following table.

| Component | Signal description |
|-----------------------|---|
| ECM | Transmits the following signals to ABS actuator and electric unit (control unit) via CAN communication. <ul style="list-style-type: none"> • Accelerator pedal position signal • Engine speed signal • Target throttle position signal |
| TCM | Transmits the current gear position signal to ABS actuator and electric unit (control unit) via CAN communication. |
| Steering angle sensor | Transmits the steering angle sensor signal to ABS actuator and electric unit (control unit) via CAN communication. |
| Combination meter | Transmits the following signals to ABS actuator and electric unit (control unit) via CAN communication. <ul style="list-style-type: none"> • Brake fluid level switch signal • Parking brake switch signal Receives the following signals from ABS actuator and electric unit (control unit) via CAN communication. <ul style="list-style-type: none"> • VDC OFF indicator lamp signal • SLIP indicator lamp signal |

VDC/TCS/ABS : ABS Function

INFOID:000000007616458

SYSTEM DIAGRAM

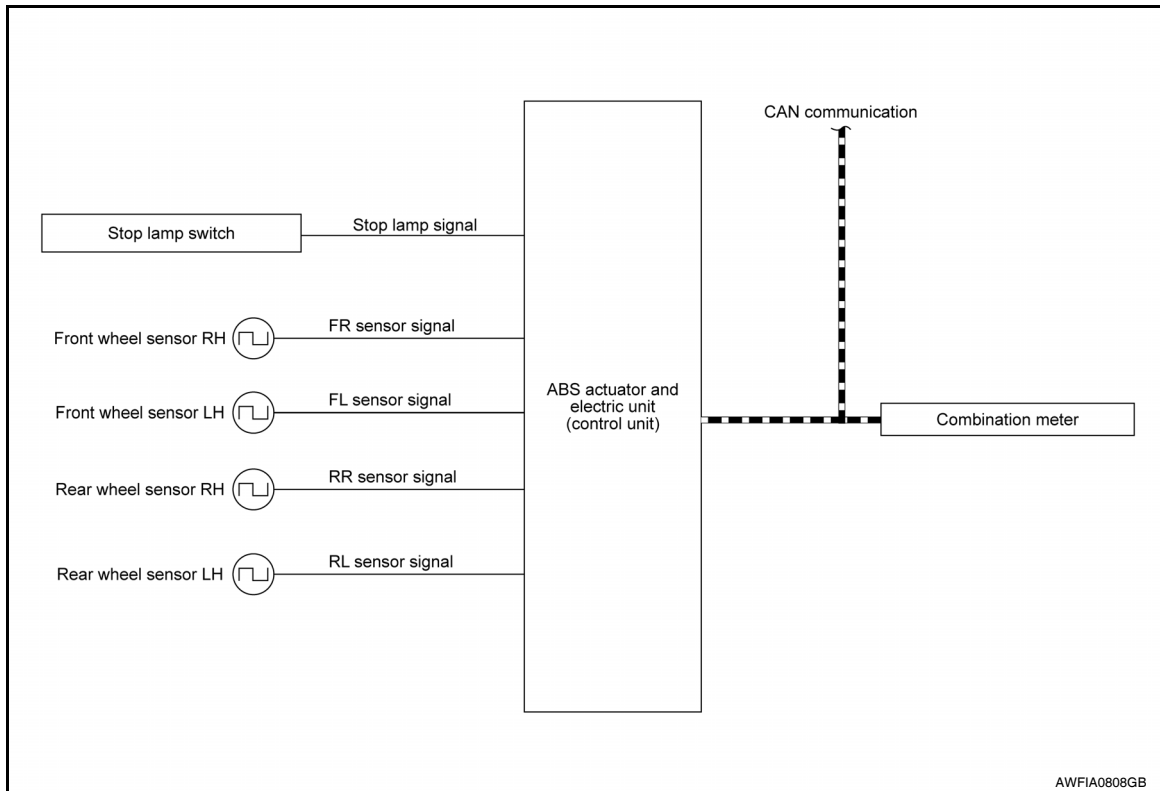

- By preventing wheel lock through brake force (brake fluid pressure) control that is electronically controlled by detecting wheel speed during braking, stability during emergency braking is improved so that obstacles can be easily bypassed by steering operation.
- During braking, control units calculate wheel speed and pseudo-vehicle speed, and transmit pressure increase, hold or decrease signals to actuator portion according to wheel slip status.
- The following effects are obtained by preventing wheel lock during braking.
 - Vehicle tail slip is prevented during braking when driving straight.
 - Understeer and oversteer tendencies are moderated during braking while cornering.
 - Obstacles may be easily bypassed by steering operation during braking.
- CONSULT can be used to diagnose the system.
- Fail-safe function is adopted. When a malfunction occurs in ABS function, the control is suspended for VDC function, TCS function and ABS function. However, EBD function operates normally. Refer to [BRC-29, "VDC/TCS/ABS : Fail-safe"](#).

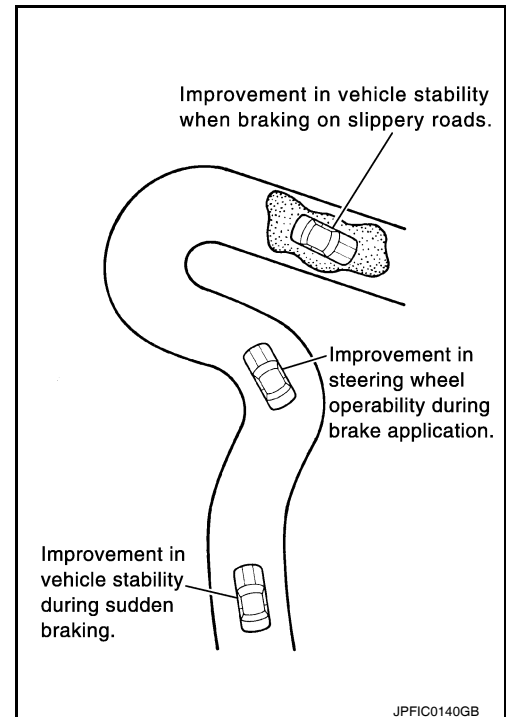

INPUT SIGNAL AND OUTPUT SIGNAL

A
B
C
D
E
BRC
G
H
I
J
K
L
M
N
O
P

SYSTEM

< SYSTEM DESCRIPTION >

[VDC/TCS/ABS]

Major signal transmission between each unit via communication lines is shown in the following table.

| Component | Signal description |
|-------------------|---|
| Combination meter | Receives the following signals from ABS actuator and electric unit (control unit) via CAN communication. <ul style="list-style-type: none"> • VDC warning lamp signal • ABS warning lamp signal |

VDC/TCS/ABS : EBD Function

INFOID:000000007616459

SYSTEM DIAGRAM

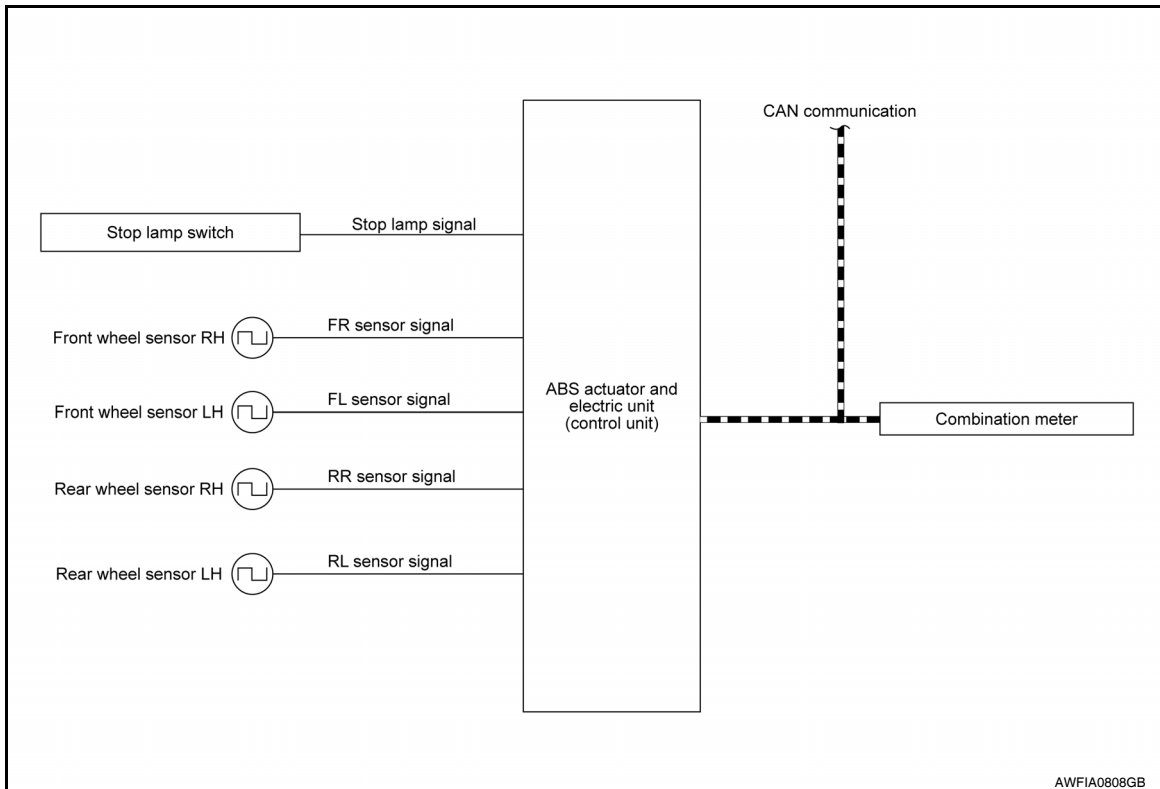

- By preventing rear wheel slip increase through rear wheel brake force (brake fluid pressure) control that is electronically controlled when slight skip on front and rear wheels are detected during braking, stability during braking is improved.
- EBD function is expanded and developed from conventional ABS function and corrects rear wheel brake force to appropriate level by electronic control according to load weight (number of passengers).

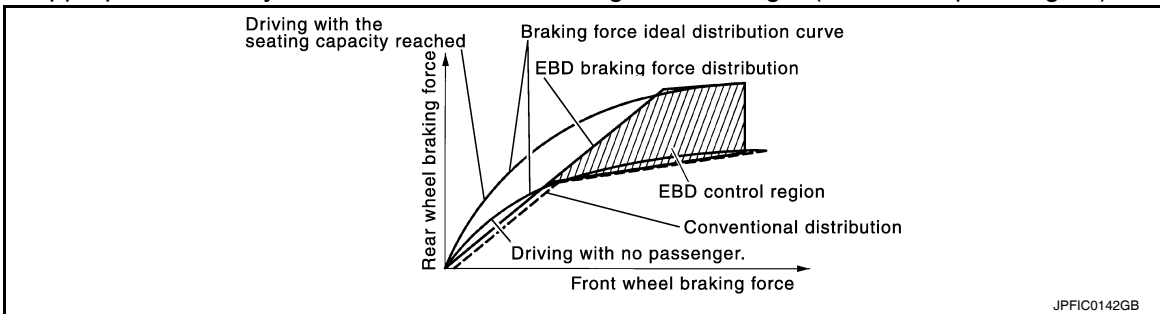

SYSTEM

< SYSTEM DESCRIPTION >

[VDC/TCS/ABS]

- During braking, control unit portion compares slight slip on front and rear wheels by wheel speed sensor signal, transmits drive signal to actuator portion when rear wheel slip exceeds front wheel slip for the specified value or more, and controls rear wheel brake force (brake fluid pressure) so that increase of rear wheel slip is prevented and slips on front wheel and rear wheel are nearly equalized. ABS control is applied when slip on each wheel increases and wheel speed is the threshold value of ABS control or less.
- CONSULT can be used to diagnose the system.
- Fail-safe function is adopted. When a malfunction occurs in EBD function, the control is suspended for VDC function, TCS function, ABS function and EBD function. Refer to [BRC-29. "VDC/TCS/ABS : Fail-safe"](#).

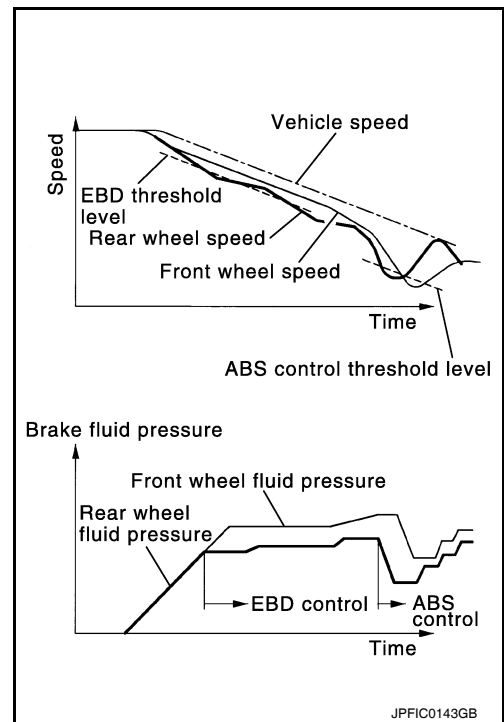

INPUT SIGNAL AND OUTPUT SIGNAL

Major signal transmission between each unit via communication lines is shown in the following table.

| Component | Signal description |
|-------------------|---|
| Combination meter | Receives the following signals from ABS actuator and electric unit (control unit) via CAN communication. <ul style="list-style-type: none"> • ABS warning lamp signal • Brake warning lamp signal • SLIP indicator lamp signal |

VDC/TCS/ABS : Fail-safe

INFOID:000000007630849

VDC AND TCS FUNCTIONS

VDC warning lamp in combination meter turns ON when a malfunction occurs in system [ABS actuator and electric unit (control unit)]. The control is suspended for VDC and TCS functions. However, ABS and EBD functions operate normally.

ABS FUNCTION

ABS warning lamp and SLIP indicator lamp in combination meter turn ON when a malfunction occurs in system [ABS actuator and electric unit (control unit)]. The control is suspended for VDC, TCS and ABS functions. However, EBD functions operate normally.

EBD FUNCTION

ABS warning lamp, brake warning lamp and SLIP indicator lamp in combination meter turn ON when a malfunction occurs in system [ABS actuator and electric unit (control unit)]. The control is suspended for VDC, TCS, ABS and EBD functions.

SYSTEM

< SYSTEM DESCRIPTION >

[VDC/TCS/ABS]

| DTC | Malfunction detected condition | Fail-safe condition | |
|-------|---|---|--|
| C1101 | When an open circuit is detected in rear RH wheel sensor circuit. | | |
| C1102 | When an open circuit is detected in rear LH wheel sensor circuit. | | |
| C1103 | When an open circuit is detected in front RH wheel sensor circuit. | | |
| C1104 | When an open circuit is detected in front LH wheel sensor circuit. | | |
| C1105 | <ul style="list-style-type: none"> • When a short circuit is detected in rear RH wheel sensor circuit. • When power supply voltage of rear RH wheel sensor is in following state. - Rear RH wheel sensor power supply voltage: $7.2\text{ V} \geq$ Rear RH wheel sensor power supply voltage • When distance between rear RH wheel sensor and rear RH wheel sensor rotor is large. • When installation of rear RH wheel sensor or rear RH wheel sensor rotor is not normal. | | |
| C1106 | <ul style="list-style-type: none"> • When a short circuit is detected in rear LH wheel sensor circuit. • When power supply voltage of rear LH wheel sensor is in following state. - Rear LH wheel sensor power supply voltage: $7.2\text{ V} \geq$ Rear LH wheel sensor power supply voltage • When distance between rear LH wheel sensor and rear LH wheel sensor rotor is large. • When installation of rear LH wheel sensor or rear LH wheel sensor rotor is not normal. | | The following functions are suspended: <ul style="list-style-type: none"> • VDC • ABS • EBD (only when both rear wheels are malfunctioning) |
| C1107 | <ul style="list-style-type: none"> • When a short circuit is detected in front RH wheel sensor circuit. • When power supply voltage of front RH wheel sensor is in following state. - Front RH wheel sensor power supply voltage: $7.2\text{ V} \geq$ Front RH wheel sensor power supply voltage • When distance between front RH wheel sensor and front RH wheel sensor rotor is large. • When installation of front RH wheel sensor or front RH wheel sensor rotor is not normal. | | |
| C1108 | <ul style="list-style-type: none"> • When a short circuit is detected in front LH wheel sensor circuit. • When power supply voltage of front LH wheel sensor is in following state. - Front LH wheel sensor power supply voltage: $7.2\text{ V} \geq$ Front LH wheel sensor power supply voltage • When distance between front LH wheel sensor and front LH wheel sensor rotor is large. • When installation of front LH wheel sensor or front LH wheel sensor rotor is not normal. | | |
| C1109 | <ul style="list-style-type: none"> • When ignition power supply voltage is in following state. - Ignition power supply voltage: $10\text{ V} \geq$ Ignition power supply voltage. - Ignition power supply voltage: $16\text{ V} \leq$ Ignition power supply voltage. | | |
| C1110 | When there is an internal malfunction in the ABS actuator and electric unit (control unit). | | |
| C1111 | When a malfunction is detected in motor or motor relay. | The following functions are suspended: <ul style="list-style-type: none"> • VDC • TCS • ABS | |
| C1115 | When difference in wheel speed between any wheel and others is detected when the vehicle is driven, because of installation of tires other than specified. | The following functions are suspended: <ul style="list-style-type: none"> • VDC • TCS • ABS • EBD | |
| C1116 | When stop lamp switch signal is not input when brake pedal operates. | The following functions are suspended: <ul style="list-style-type: none"> • VDC • TCS | |

SYSTEM

< SYSTEM DESCRIPTION >

[VDC/TCS/ABS]

| DTC | Malfunction detected condition | Fail-safe condition | |
|-------|---|--|---|
| C1120 | When a malfunction is detected in front LH ABS IN valve. | The following functions are suspended: • VDC • TCS • ABS • EBD | A |
| C1121 | When a malfunction is detected in front LH ABS OUT valve. | | B |
| C1122 | When a malfunction is detected in front RH ABS IN valve. | | C |
| C1123 | When a malfunction is detected in front RH ABS OUT valve. | | D |
| C1124 | When a malfunction is detected in rear LH ABS IN valve. | | E |
| C1125 | When a malfunction is detected in rear LH ABS OUT valve. | | E |
| C1126 | When a malfunction is detected in rear RH ABS IN valve. | | E |
| C1127 | When a malfunction is detected in rear RH ABS OUT valve. | | E |
| C1130 | When a malfunction is detected in ECM system. | The following functions are suspended: • VDC • TCS | E |
| C1140 | When a malfunction is detected in actuator relay. | The following functions are suspended: • VDC • TCS • ABS • EBD | BRC |
| C1142 | When a malfunction is detected in VDC pressure sensor. | The following functions are suspended: • VDC • TCS | G |
| C1143 | When a malfunction is detected in steering angle sensor. | | H |
| C1144 | When neutral position adjustment of steering angle sensor is not complete. | | H |
| C1145 | When a malfunction is detected in yaw rate signal, or signal line of yaw rate/side/ decel G sensor is open or shorted. | | I |
| C1146 | When a malfunction is detected in side G signal, or signal line of yaw rate/side/dec el G sensor is open or shorted. | | I |
| C1153 | When ABS actuator and electric unit (control unit) is malfunctioning. (Pressure increase is too much or too little.) | | The following functions are suspended: • VDC • TCS • ABS |
| C1155 | When brake fluid level low signal is detected. | The following functions are suspended: • VDC • TCS | K |
| C1164 | When a malfunction is detected in cut valve 1. | The following functions are suspended: • VDC • TCS • ABS • EBD | L |
| C1165 | When a malfunction is detected in cut valve 2. | | M |
| C1166 | When a malfunction is detected in suction valve 1. | | M |
| C1167 | When a malfunction is detected in suction valve 2. | | M |
| C1170 | When the information in ABS actuator and electric unit (control unit) is not the same. | The following functions are suspended: • VDC • TCS • ABS | N |
| U1000 | When CAN communication signal is not continuously transmitted or received for 2 seconds or more. | The following functions are suspended: • VDC • TCS | O |
| U1002 | When ABS actuator and electric unit (control unit) is not transmitting or receiving CAN communication signal for 2 seconds or less. | | P |

DIAGNOSIS SYSTEM [ABS ACTUATOR AND ELECTRIC UNIT (CONTROL UNIT)]

< SYSTEM DESCRIPTION >

[VDC/TCS/ABS]

DIAGNOSIS SYSTEM [ABS ACTUATOR AND ELECTRIC UNIT (CONTROL UNIT)]

CONSULT Function (ABS)

INFOID:000000007616461

FUNCTION

CONSULT can display each diagnostic item using the following direct diagnostic modes.

| Direct Diagnostic Mode | Description |
|------------------------|--|
| ECU identification | The ABS actuator and electric unit (control unit) part number is displayed. |
| Self Diagnostic Result | The ABS actuator and electric unit (control unit) self diagnostic results are displayed. |
| Data Monitor | The ABS actuator and electric unit (control unit) input/output data is displayed in real time. |
| Active Test | The ABS actuator and electric unit (control unit) activates outputs to test components. |
| Work support | The settings for ABS actuator and electric unit (control unit) functions can be changed. |
| CAN DIAG SUPPORT MNTR | The result of transmit/receive diagnosis of CAN communication is displayed. |

ECU IDENTIFICATION

ABS actuator and electric unit (control unit) part number is displayed.

SELF DIAGNOSTIC RESULT

Operation Procedure

1. Before performing the self-diagnosis, start engine and drive vehicle at 30 km/h (19 MPH) or more for approximately 1 minute.

How To Erase Self Diagnostic Result

1. After erasing DTC memory, start engine and drive vehicle at 30 km/h (19 MPH) or more for approximately 1 minute as the final inspection, and make sure that the ABS warning lamp, VDC OFF indicator lamp, SLIP indicator lamp and brake warning lamp turn OFF.

CAUTION:

If memory cannot be erased, perform applicable diagnosis.

NOTE:

- When the wheel sensor malfunctions, after inspecting the wheel sensor system, the ABS warning lamp, VDC OFF indicator lamp, SLIP indicator lamp and brake warning lamp will not turn OFF even when the system is normal, unless the vehicle is driven at approximately 30 km/h (19 MPH) or more for approximately 1 minute.
- Brake warning lamp will turn ON in case of parking brake operation (when switch is ON) or of brake fluid level switch operation (when brake fluid is insufficient).
- VDC OFF switch should not stay in ON position.

Display Item List

Refer to [BRC-42, "DTC Index"](#).

DATA MONITOR

| Item (Unit) | Data monitor item selection | | | Remarks |
|-----------------------------|-----------------------------|-----------------|------------------------|--|
| | ECU INPUT SIGNALS | MAIN SIGNALS | SELECTION FROM MENU | |
| FR LH SENSOR (km/h, mph) | × | × | × | Wheel speed (km/h, mph) calculated by front wheel sensor LH signal is displayed. |
| FR RH SENSOR (km/h, mph) | × | × | × | Wheel speed (km/h, mph) calculated by front wheel sensor RH signal is displayed. |
| RR LH SENSOR (km/h, mph) | × | × | × | Wheel speed (km/h, mph) calculated by rear wheel sensor LH signal is displayed. |
| RR RH SENSOR (km/h, mph) | × | × | × | Wheel speed (km/h, mph) calculated by rear wheel sensor RH signal is displayed. |

DIAGNOSIS SYSTEM [ABS ACTUATOR AND ELECTRIC UNIT (CONTROL UNIT)]

< SYSTEM DESCRIPTION >

[VDC/TCS/ABS]

| Item (Unit) | Data monitor item selection | | | Remarks |
|-----------------------------------|-----------------------------|--------------|---------------------|--|
| | ECU INPUT SIGNALS | MAIN SIGNALS | SELECTION FROM MENU | |
| DECEL G-SEN (G) | × | × | × | Longitudinal acceleration (G) detected by decel G-sensor is displayed. |
| FR RH IN SOL (On/Off) | - | × | × | Front RH IN ABS solenoid (On/Off) status is displayed. |
| FR RH OUT SOL (On/Off) | - | × | × | Front RH OUT ABS solenoid (On/Off) status is displayed. |
| FR LH IN SOL (On/Off) | - | × | × | Front LH IN ABS solenoid (On/Off) status is displayed. |
| FR LH OUT SOL (On/Off) | - | × | × | Front LH OUT ABS solenoid (On/Off) status is displayed. |
| RR RH IN SOL (On/Off) | - | × | × | Rear RH IN ABS solenoid (On/Off) status is displayed. |
| RR RH OUT SOL (On/Off) | - | × | × | Rear RH OUT ABS solenoid (On/Off) status is displayed. |
| RR LH IN SOL (On/Off) | - | × | × | Rear LH IN ABS solenoid (On/Off) status is displayed. |
| RR LH OUT SOL (On/Off) | - | × | × | Rear LH OUT ABS solenoid (On/Off) status is displayed. |
| EBD WARN LAMP (On/Off) | - | - | × | Brake warning lamp (On/Off) status is displayed. |
| STOP LAMP SW (On/Off) | × | × | × | Stop lamp switch (On/Off) status is displayed. |
| MOTOR RELAY (On/Off) | - | × | × | ABS motor relay signal (On/Off) status is displayed. |
| ACTUATOR RLY (On/Off) | - | × | × | ABS actuator relay signal (On/Off) status is displayed. |
| ABS WARN LAMP (On/Off) | - | × | × | ABS warning lamp (On/Off) status is displayed. |
| OFF LAMP (On/Off) | - | × | × | VDC OFF Lamp (On/Off) status is displayed. |
| SLIP/VDC LAMP (On/Off) | - | × | × | SLIP indicator lamp (On/Off) status is displayed. |
| BATTERY VOLT (V) | × | × | × | Voltage (V) supplied to ABS actuator and electric unit (control unit) is displayed. |
| GEAR (1, 2, 3, 4, 5) | × | × | × | Gear position (1, 2, 3, 4, 5) judged by transmission range switch signal is displayed. |
| YAW RATE SEN (d/s) | × | × | × | Yaw rate (d/s) detected by yaw rate sensor is displayed. |
| R POSI SIG (On/Off) | - | - | × | Reverse shift position (On/Off) judged by transmission range switch signal. |
| N POSI SIG (On/Off) | - | - | × | Neutral position (On/Off) judged by transmission range switch signal. |
| P POSI SIG (On/Off) | - | - | × | Park position (On/Off) judged by transmission range switch signal. |
| ACCEL POS SIG (%) | × | - | × | Throttle valve open/close status judged by CAN communication signal is displayed. |
| SIDE G-SENSOR (m/s ²) | × | - | × | Transverse acceleration detected by side G-sensor is displayed. |
| STR ANGLE SIG (deg) | × | - | × | Steering angle detected by steering angle sensor is displayed. |

A

B

C

D

E

BRC

G

H

I

J

K

L

M

N

O

P

DIAGNOSIS SYSTEM [ABS ACTUATOR AND ELECTRIC UNIT (CONTROL UNIT)]

< SYSTEM DESCRIPTION >

[VDC/TCS/ABS]

| Item (Unit) | Data monitor item selection | | | Remarks |
|---------------------------|-----------------------------|-----------------|------------------------|---|
| | ECU INPUT SIGNALS | MAIN SIGNALS | SELECTION FROM MENU | |
| PRESS SENSOR (bar) | × | - | × | Brake pressure detected by pressure sensor is displayed. |
| EBD SIGNAL (On/Off) | - | - | × | EBD operation (On/Off) status is displayed. |
| ABS SIGNAL (On/Off) | - | - | × | ABS operation (On/Off) status is displayed. |
| TCS SIGNAL (On/Off) | - | - | × | TCS operation (On/Off) status is displayed. |
| VDC SIGNAL (On/Off) | - | - | × | VDC operation (On/Off) status is displayed. |
| EBD FAIL SIG (On/Off) | - | - | × | EBD fail signal (On/Off) status is displayed. |
| ABS FAIL SIG (On/Off) | - | - | × | ABS fail signal (On/Off) status is displayed. |
| TCS FAIL SIG (On/Off) | - | - | × | TCS fail signal (On/Off) status is displayed. |
| VDC FAIL SIG (On/Off) | - | - | × | VDC fail signal (On/Off) status is displayed. |
| CRANKING SIG (On/Off) | - | - | × | The input state of the key SW START position signal is displayed. |
| FLUID LEV SW (On/Off) | × | - | × | Brake fluid level switch (On/Off) status is displayed. |
| PARK BRAKE SW (On/Off) | - | - | × | Park brake switch (On/Off) status is displayed. |
| USV[FL-RR] (On/Off) | — | — | × | Primary side USV solenoid valve (On/Off) status is displayed. |
| USV[FR-RL] (On/Off) | — | — | × | Secondary side USV solenoid valve (On/Off) status is displayed. |
| HSV[FL-RR] (On/Off) | — | — | × | Primary side HSV solenoid valve (On/Off) status is displayed. |
| HSV[FR-RL] (On/Off) | — | — | × | Secondary side HSV solenoid valve (On/Off) status is displayed. |
| V/R OUTPUT (On/Off) | — | — | × | Valve relay operation signal (On/Off) status is displayed. |
| M/R OUTPUT (On/Off) | — | — | × | Motor relay operation signal (On/Off) status is displayed. |
| ENGINE RPM (tr/min) | × | - | × | Engine speed judged by CAN communication signal is displayed. |

×: Applicable

-: Not applicable

ACTIVE TEST

CAUTION:

- Do not perform active test while driving vehicle.
- Make sure to completely bleed air from brake system.
- The active test cannot be performed with the ABS warning lamp, VDC OFF indicator lamp, SLIP indicator lamp or brake warning lamp on.
- ABS warning lamp, VDC OFF indicator lamp, SLIP indicator lamp and brake warning lamp turn on during active test.

NOTE:

- When active test is performed while depressing the pedal, the pedal depression amount will change. This is normal.
- “TEST IS STOPPED” is displayed 10 seconds after operation start.

DIAGNOSIS SYSTEM [ABS ACTUATOR AND ELECTRIC UNIT (CONTROL UNIT)]

< SYSTEM DESCRIPTION >

[VDC/TCS/ABS]

- After “TEST IS STOPPED” is displayed, to perform test again, touch BACK.

Test Item

ABS MOTOR

- Touch “On” and “Off” on screen. Make sure motor relay and actuator relay operate as shown in table below.

| Operation | On | Off |
|--------------|----|-----|
| MOTOR RELAY | On | Off |
| ACTUATOR RLY | On | On |

WORK SUPPORT

| Conditions | Description |
|----------------------------|---|
| ST ANGLE SENSOR ADJUSTMENT | Steering angle sensor neutral position adjustment can be performed. Refer to BRC-54 . "Work Procedure". |

A

B

C

D

E

BRC

G

H

I

J

K

L

M

N

O

P

ABS ACTUATOR AND ELECTRIC UNIT (CONTROL UNIT)

< ECU DIAGNOSIS INFORMATION >

[VDC/TCS/ABS]

ECU DIAGNOSIS INFORMATION

ABS ACTUATOR AND ELECTRIC UNIT (CONTROL UNIT)

Reference Value

INFOID:000000007616462

VALUES ON THE DIAGNOSIS TOOL

CAUTION:

The display shows the control unit calculation data, so a normal value might be displayed even in the event the output circuit (harness) is open or short-circuited.

| Monitor item | Display content | Data monitor | |
|---------------|--|--|-------------------------------------|
| | | Condition | Reference value in normal operation |
| FR LH SENSOR | Wheel speed | 0 [km/h, mph] | Vehicle stopped |
| | | Nearly matches the speed meter display (± 10% or less) | Vehicle running (Note 1) |
| FR RH SENSOR | Wheel speed | 0 [km/h, mph] | Vehicle stopped |
| | | Nearly matches the speed meter display (± 10% or less) | Vehicle running (Note 1) |
| RR LH SENSOR | Wheel speed | 0 [km/h, mph] | Vehicle stopped |
| | | Nearly matches the speed meter display (± 10% or less) | Vehicle running (Note 1) |
| RR RH SENSOR | Wheel speed | 0 [km/h, mph] | Vehicle stopped |
| | | Nearly matches the speed meter display (± 10% or less) | Vehicle running (Note 1) |
| DECEL G-SEN | Longitudinal acceleration detected by decel G sensor | Vehicle stopped | Approx. 0 G |
| | | Vehicle running | -1.7 to 1.7 G |
| FR RH IN SOL | Operation status of all solenoid valves | Actuator (solenoid valve) is active ("ACTIVE TEST" with CONSULT) or actuator relay is inactive (in fail-safe mode) | On |
| | | When the actuator (solenoid valve) is not active and actuator relay is active (ignition switch ON) | Off |
| FR RH OUT SOL | Operation status of all solenoid valves | Actuator (solenoid valve) is active ("ACTIVE TEST" with CONSULT) or actuator relay is inactive (in fail-safe mode) | On |
| | | When the actuator (solenoid valve) is not active and actuator relay is active (ignition switch ON) | Off |
| FR LH IN SOL | Operation status of all solenoid valves | Actuator (solenoid valve) is active ("ACTIVE TEST" with CONSULT) or actuator relay is inactive (in fail-safe mode) | On |
| | | When the actuator (solenoid valve) is not active and actuator relay is active (ignition switch ON) | Off |
| FR LH OUT SOL | Operation status of all solenoid valves | Actuator (solenoid valve) is active ("ACTIVE TEST" with CONSULT) or actuator relay is inactive (in fail-safe mode) | On |
| | | When the actuator (solenoid valve) is not active and actuator relay is active (ignition switch ON) | Off |

ABS ACTUATOR AND ELECTRIC UNIT (CONTROL UNIT)

< ECU DIAGNOSIS INFORMATION >

[VDC/TCS/ABS]

| Monitor item | Display content | Data monitor | |
|---------------|---|--|-------------------------------------|
| | | Condition | Reference value in normal operation |
| RR RH IN SOL | Operation status of all solenoid valves | Actuator (solenoid valve) is active ("ACTIVE TEST" with CONSULT) or actuator relay is inactive (in fail-safe mode) | On |
| | | When the actuator (solenoid valve) is not active and actuator relay is active (ignition switch ON) | Off |
| RR RH OUT SOL | Operation status of all solenoid valves | Actuator (solenoid valve) is active ("ACTIVE TEST" with CONSULT) or actuator relay is inactive (in fail-safe mode) | On |
| | | When the actuator (solenoid valve) is not active and actuator relay is active (ignition switch ON) | Off |
| RR LH IN SOL | Operation status of all solenoid valves | Actuator (solenoid valve) is active ("ACTIVE TEST" with CONSULT) or actuator relay is inactive (in fail-safe mode) | On |
| | | When the actuator (solenoid valve) is not active and actuator relay is active (ignition switch ON) | Off |
| RR LH OUT SOL | Operation status of all solenoid valves | Actuator (solenoid valve) is active ("ACTIVE TEST" with CONSULT) or actuator relay is inactive (in fail-safe mode) | On |
| | | When the actuator (solenoid valve) is not active and actuator relay is active (ignition switch ON) | Off |
| EBD WARN LAMP | EBD warning lamp (Note 2) | When EBD warning lamp is ON | On |
| | | When EBD warning lamp is OFF | Off |
| STOP LAMP SW | Brake pedal operation | When brake pedal is depressed | On |
| | | When brake pedal is not depressed | Off |
| MOTOR RELAY | Motor and motor relay operation | When the motor relay and motor are operating | On |
| | | When the motor relay and motor are not operating | Off |
| ACTUATOR RLY | Actuator relay operation | When the actuator relay is operating | On |
| | | When the actuator relay is not operating | Off |
| ABS WARN LAMP | ABS warning lamp (Note 2) | When ABS warning lamp is ON | On |
| | | When ABS warning lamp is OFF | Off |
| OFF LAMP | VDC OFF indicator lamp (Note 2) | When VDC OFF indicator lamp is ON | On |
| | | When VDC OFF indicator lamp is OFF | Off |
| SLIP/VDC LAMP | SLIP indicator lamp (Note 2) | When SLIP indicator lamp is ON | On |
| | | When SLIP indicator lamp is OFF | Off |
| BATTERY VOLT | Battery voltage supplied to the ABS actuator and electric unit (control unit) | Ignition switch ON | 10 – 16 V |
| GEAR | Manual mode gear position determined by TCM | 1st gear 2nd gear 3rd gear 4th gear 5th gear | 1 2 3 4 5 |
| YAW RATE SEN | Yaw rate detected by yaw rate/side G sensor | When vehicle stop | Approx. 0 d/s |
| | | When vehicle turning | -75 to 75 d/s |

A
B
C
D
E
BRC
G
H
I
J
K
L
M
N
O
P

ABS ACTUATOR AND ELECTRIC UNIT (CONTROL UNIT)

< ECU DIAGNOSIS INFORMATION >

[VDC/TCS/ABS]

| Monitor item | Display content | Data monitor | |
|---------------|--|--|-------------------------------------|
| | | Condition | Reference value in normal operation |
| R POSI SIG | Transmission range switch signal ON/OFF condition | CVT shift position = R position | On |
| | | CVT shift position = other than R position | Off |
| N POSI SIG | Transmission range switch signal ON/OFF condition | CVT shift position = N position | On |
| | | CVT shift position = other than N position | Off |
| P POSI SIG | Transmission range switch signal ON/OFF condition | CVT shift position = P position | On |
| | | CVT shift position = other than P position | Off |
| ACCEL POS SIG | Throttle actuator opening/closing is displayed (linked with accelerator pedal) | Accelerator pedal not depressed (ignition switch is ON) | 0 % |
| | | Depress accelerator pedal (ignition switch is ON) | 0 - 100 % |
| SIDE G-SENSOR | Transverse G detected by side G sensor | Vehicle stopped | Approx. 0 m/s ² |
| | | Vehicle turning right | Negative value (m/s ²) |
| | | Vehicle turning left | Positive value (m/s ²) |
| STR ANGLE SIG | Steering angle detected by steering angle sensor | Straight-ahead | Approx. 0° |
| | | Steering wheel turned | -720 to 720° |
| PRESS SENSOR | Brake fluid pressure detected by pressure sensor | With ignition switch turned ON and brake pedal released | Approx. 0 bar |
| | | With ignition switch turned ON and brake pedal depressed | -40 to 300 bar |
| EBD SIGNAL | EBD operation | EBD is active | On |
| | | EBD is inactive | Off |
| ABS SIGNAL | ABS operation | ABS is active | On |
| | | ABS is inactive | Off |
| TCS SIGNAL | TCS operation | TCS is active | On |
| | | TCS is inactive | Off |
| VDC SIGNAL | VDC operation | VDC is active | On |
| | | VDC is inactive | Off |
| EBD FAIL SIG | EBD fail-safe signal | In EBD fail-safe | On |
| | | EBD is normal | Off |
| ABS FAIL SIG | ABS fail-safe signal | In ABS fail-safe | On |
| | | ABS is normal | Off |
| TCS FAIL SIG | TCS fail-safe signal | In TCS fail-safe | On |
| | | TCS is normal | Off |
| VDC FAIL SIG | VDC fail-safe signal | In VDC fail-safe | On |
| | | VDC is normal | Off |
| CRANKING SIG | Crank operation | Crank is active | On |
| | | Crank is inactive | Off |
| FLUID LEV SW | Brake fluid level switch | When brake fluid level switch ON | On |
| | | When brake fluid level switch OFF | Off |
| PARK BRAKE SW | Parking brake switch | Parking brake switch is active | On |
| | | Parking brake switch is inactive | Off |

ABS ACTUATOR AND ELECTRIC UNIT (CONTROL UNIT)

< ECU DIAGNOSIS INFORMATION >

[VDC/TCS/ABS]

| Monitor item | Display content | Data monitor | |
|--------------|--|---|--|
| | | Condition | Reference value in normal operation |
| USV[FL-RR] | VDC switch-over valve | When actuator (switch-over valve) is active ("ACTIVE TEST" with CONSULT) or actuator relay is inactive (when in fail-safe mode) | On |
| | | When actuator (switch-over valve) is not active and actuator relay is active (ignition switch ON) | Off |
| USV[FR-RL] | VDC switch-over valve | When actuator (switch-over valve) is active ("ACTIVE TEST" with CONSULT) or actuator relay is inactive (when in fail-safe mode) | On |
| | | When actuator (switch-over valve) is not active and actuator relay is active (ignition switch ON) | Off |
| HSV[FL-RR] | VDC switch-over valve | When actuator (switch-over valve) is active ("ACTIVE TEST" with CONSULT) or actuator relay is inactive (when in fail-safe mode) | On |
| | | When actuator (switch-over valve) is not active and actuator relay is active (ignition switch ON) | Off |
| HSV[FR-RL] | VDC switch-over valve | When actuator (switch-over valve) is active ("ACTIVE TEST" with CONSULT) or actuator relay is inactive (when in fail-safe mode) | On |
| | | When actuator (switch-over valve) is not active and actuator relay is active (ignition switch ON) | Off |
| V/R OUTPUT | Solenoid valve relay activated | When the solenoid valve relay is active (when ignition switch OFF) | On |
| | | When the solenoid valve relay is not active (in the fail-safe mode) | Off |
| M/R OUTPUT | Actuator motor and motor relay activated | When the actuator motor and motor relay are active ("ACTIVE TEST" with CONSULT) | On |
| | | When the actuator motor and motor relay are inactive | Off |
| ENGINE RPM | With engine running | With engine stopped | 0 rpm |
| | | Engine running | Almost in accordance with tachometer display |

Note 1: Confirm tire pressure is normal.

Note 2: On and off timing for warning lamps and indicator lamps.

- Refer to [BRC-23. "VDC/TCS/ABS : VDC Function"](#).
- Refer to [BRC-25. "VDC/TCS/ABS : TCS Function"](#).
- Refer to [BRC-27. "VDC/TCS/ABS : ABS Function"](#).
- Refer to [BRC-28. "VDC/TCS/ABS : EBD Function"](#).

Fail-safe

INFOID:000000007616463

VDC AND TCS FUNCTIONS

VDC warning lamp in combination meter turns ON when a malfunction occurs in system [ABS actuator and electric unit (control unit)]. The control is suspended for VDC and TCS functions. However, ABS and EBD functions operate normally.

ABS ACTUATOR AND ELECTRIC UNIT (CONTROL UNIT)

< ECU DIAGNOSIS INFORMATION >

[VDC/TCS/ABS]

ABS FUNCTION

ABS warning lamp and SLIP indicator lamp in combination meter turn ON when a malfunction occurs in system [ABS actuator and electric unit (control unit)]. The control is suspended for VDC, TCS and ABS functions. However, EBD functions operate normally.

EBD FUNCTION

ABS warning lamp, brake warning lamp and SLIP indicator lamp in combination meter turn ON when a malfunction occurs in system [ABS actuator and electric unit (control unit)]. The control is suspended for VDC, TCS, ABS and EBD functions.

| DTC | Malfunction detected condition | Fail-safe condition | |
|-------|---|---|--|
| C1101 | When an open circuit is detected in rear RH wheel sensor circuit. | <p>The following functions are suspended:</p> <ul style="list-style-type: none"> • VDC • ABS • EBD (only when both rear wheels are malfunctioning) | |
| C1102 | When an open circuit is detected in rear LH wheel sensor circuit. | | |
| C1103 | When an open circuit is detected in front RH wheel sensor circuit. | | |
| C1104 | When an open circuit is detected in front LH wheel sensor circuit. | | |
| C1105 | <ul style="list-style-type: none"> • When a short circuit is detected in rear RH wheel sensor circuit. • When power supply voltage of rear RH wheel sensor is in following state. - Rear RH wheel sensor power supply voltage: $7.2\text{ V} \geq$ Rear RH wheel sensor power supply voltage • When distance between rear RH wheel sensor and rear RH wheel sensor rotor is large. • When installation of rear RH wheel sensor or rear RH wheel sensor rotor is not normal. | | |
| C1106 | <ul style="list-style-type: none"> • When a short circuit is detected in rear LH wheel sensor circuit. • When power supply voltage of rear LH wheel sensor is in following state. - Rear LH wheel sensor power supply voltage: $7.2\text{ V} \geq$ Rear LH wheel sensor power supply voltage • When distance between rear LH wheel sensor and rear LH wheel sensor rotor is large. • When installation of rear LH wheel sensor or rear LH wheel sensor rotor is not normal. | | |
| C1107 | <ul style="list-style-type: none"> • When a short circuit is detected in front RH wheel sensor circuit. • When power supply voltage of front RH wheel sensor is in following state. - Front RH wheel sensor power supply voltage: $7.2\text{ V} \geq$ Front RH wheel sensor power supply voltage • When distance between front RH wheel sensor and front RH wheel sensor rotor is large. • When installation of front RH wheel sensor or front RH wheel sensor rotor is not normal. | | |
| C1108 | <ul style="list-style-type: none"> • When a short circuit is detected in front LH wheel sensor circuit. • When power supply voltage of front LH wheel sensor is in following state. - Front LH wheel sensor power supply voltage: $7.2\text{ V} \geq$ Front LH wheel sensor power supply voltage • When distance between front LH wheel sensor and front LH wheel sensor rotor is large. • When installation of front LH wheel sensor or front LH wheel sensor rotor is not normal. | | |
| C1109 | <ul style="list-style-type: none"> • When ignition power supply voltage is in following state. - Ignition power supply voltage: $10\text{ V} \geq$ Ignition power supply voltage. - Ignition power supply voltage: $16\text{ V} \leq$ Ignition power supply voltage. | | <p>The following functions are suspended:</p> <ul style="list-style-type: none"> • VDC • TCS • ABS • EBD |
| C1110 | When there is an internal malfunction in the ABS actuator and electric unit (control unit). | | |
| C1111 | When a malfunction is detected in motor or motor relay. | | <p>The following functions are suspended:</p> <ul style="list-style-type: none"> • VDC • TCS • ABS |

ABS ACTUATOR AND ELECTRIC UNIT (CONTROL UNIT)

< ECU DIAGNOSIS INFORMATION >

[VDC/TCS/ABS]

| DTC | Malfunction detected condition | Fail-safe condition | |
|-------|--|--|------------|
| C1115 | When difference in wheel speed between any wheel and others is detected when the vehicle is driven, because of installation of tires other than specified. | The following functions are suspended: • VDC • TCS • ABS • EBD | A |
| C1116 | When stop lamp switch signal is not input when brake pedal operates. | The following functions are suspended: • VDC • TCS | B |
| C1120 | When a malfunction is detected in front LH ABS IN valve. | The following functions are suspended: • VDC • TCS • ABS • EBD | C |
| C1121 | When a malfunction is detected in front LH ABS OUT valve. | | D |
| C1122 | When a malfunction is detected in front RH ABS IN valve. | | E |
| C1123 | When a malfunction is detected in front RH ABS OUT valve. | | BRC |
| C1124 | When a malfunction is detected in rear LH ABS IN valve. | | |
| C1125 | When a malfunction is detected in rear LH ABS OUT valve. | | |
| C1126 | When a malfunction is detected in rear RH ABS IN valve. | | |
| C1127 | When a malfunction is detected in rear RH ABS OUT valve. | | |
| C1130 | When a malfunction is detected in ECM system. | The following functions are suspended: • VDC • TCS | G |
| C1140 | When a malfunction is detected in actuator relay. | The following functions are suspended: • VDC • TCS • ABS • EBD | H |
| C1142 | When a malfunction is detected in VDC pressure sensor. | The following functions are suspended: • VDC • TCS | I |
| C1143 | When a malfunction is detected in steering angle sensor. | | J |
| C1144 | When neutral position adjustment of steering angle sensor is not complete. | | K |
| C1145 | When a malfunction is detected in yaw rate signal, or signal line of yaw rate/side/ decel G sensor is open or shorted. | | |
| C1146 | When a malfunction is detected in side G signal, or signal line of yaw rate/side/dec el G sensor is open or shorted. | | |
| C1153 | When ABS actuator and electric unit (control unit) is malfunctioning. (Pressure increase is too much or too little.) | The following functions are suspended: • VDC • TCS • ABS | L |
| C1155 | When brake fluid level low signal is detected. | The following functions are suspended: • VDC • TCS | M |
| C1164 | When a malfunction is detected in cut valve 1. | The following functions are suspended: • VDC • TCS • ABS • EBD | N |
| C1165 | When a malfunction is detected in cut valve 2. | | O |
| C1166 | When a malfunction is detected in suction valve 1. | | P |
| C1167 | When a malfunction is detected in suction valve 2. | | |
| C1170 | When the information in ABS actuator and electric unit (control unit) is not the same. | The following functions are suspended: • VDC • TCS • ABS | |

ABS ACTUATOR AND ELECTRIC UNIT (CONTROL UNIT)

< ECU DIAGNOSIS INFORMATION >

[VDC/TCS/ABS]

| DTC | Malfunction detected condition | Fail-safe condition |
|-------|---|--|
| U1000 | When CAN communication signal is not continuously transmitted or received for 2 seconds or more. | The following functions are suspended: • VDC • TCS |
| U1002 | When ABS actuator and electric unit (control unit) is not transmitting or receiving CAN communication signal for 2 seconds or less. | |

DTC Inspection Priority Chart

INFOID:000000007616464

When multiple DTCs are displayed simultaneously, check each one using the following priority list.

| Priority | Detected item (DTC) |
|----------|--|
| 1 | <ul style="list-style-type: none"> • U1000 CAN COMM CIRCUIT • U1002 SYSTEM COMM(CAN) |
| 2 | <ul style="list-style-type: none"> • C1110 CONTROLLER FAILURE • C1153 EMERGENCY BRAKE • C1170 VARIANT CORDING |
| 3 | <ul style="list-style-type: none"> • C1130 ENGINE SIGNAL 1 • C1144 ST ANG SEN SIGNAL |
| 4 | <ul style="list-style-type: none"> • C1109 BATTERY VOLTAGE [ABNORMAL] • C1111 PUMP MOTOR • C1140 ACTUATOR RLY |
| 5 | <ul style="list-style-type: none"> • C1101 RR RH SENSOR-1 • C1102 RR LH SENSOR-1 • C1103 FR RH SENSOR-1 • C1104 FR LH SENSOR-1 • C1105 RR RH SENSOR-2 • C1106 RR LH SENSOR-2 • C1107 FR RH SENSOR-2 • C1108 FR LH SENSOR-2 • C1115 ABS SENSOR [ABNORMAL SIGNAL] • C1116 STOP LAMP SW • C1120 FR LH IN ABS SOL • C1121 FR LH OUT ABS SOL • C1122 FR RH IN ABS SOL • C1123 FR RH OUT ABS SOL • C1124 RR LH IN ABS SOL • C1125 RR LH OUT ABS SOL • C1126 RR RH IN ABS SOL • C1127 RR RH OUT ABS SOL • C1142 PRESS SEN CIRCUIT • C1143 ST ANG SEN CIRCUIT • C1145 YAW RATE SENSOR • C1146 SIDE G-SEN CIRCUIT • C1164 CV1 • C1165 CV2 • C1166 SV1 • C1167 SV2 |
| 6 | <ul style="list-style-type: none"> • C1155 BR FLUID LEVEL LOW |

DTC Index

INFOID:000000007616465

| DTC | Items (CONSULT screen terms) | Reference |
|-------|------------------------------|-------------------------------------|
| C1101 | RR RH SENSOR-1 | BRC-56, "DTC Logic" |
| C1102 | RR LH SENSOR-1 | |
| C1103 | FR RH SENSOR-1 | |
| C1104 | FR LH SENSOR-1 | |

ABS ACTUATOR AND ELECTRIC UNIT (CONTROL UNIT)

< ECU DIAGNOSIS INFORMATION >

[VDC/TCS/ABS]

| DTC | Items (CONSULT screen terms) | Reference | |
|-------|------------------------------|-------------------------------------|------------|
| C1105 | RR RH SENSOR-2 | BRC-58, "DTC Logic" | A |
| C1106 | RR LH SENSOR-2 | | |
| C1107 | FR RH SENSOR-2 | | B |
| C1108 | FR LH SENSOR-2 | | |
| C1109 | BATTERY VOLTAGE [ABNORMAL] | BRC-60, "DTC Logic" | |
| C1110 | CONTROLLER FAILURE | BRC-62, "DTC Logic" | C |
| C1111 | PUMP MOTOR | BRC-63, "DTC Logic" | |
| C1115 | ABS SENSOR [ABNORMAL SIGNAL] | BRC-65, "DTC Logic" | D |
| C1116 | STOP LAMP SW | BRC-67, "DTC Logic" | |
| C1120 | FR LH IN ABS SOL | BRC-69, "DTC Logic" | |
| C1121 | FR LH OUT ABS SOL | BRC-71, "DTC Logic" | E |
| C1122 | FR RH IN ABS SOL | BRC-69, "DTC Logic" | |
| C1123 | FR RH OUT ABS SOL | BRC-71, "DTC Logic" | BRC |
| C1124 | RR LH IN ABS SOL | BRC-69, "DTC Logic" | |
| C1125 | RR LH OUT ABS SOL | BRC-71, "DTC Logic" | |
| C1126 | RR RH IN ABS SOL | BRC-69, "DTC Logic" | G |
| C1127 | RR RH OUT ABS SOL | BRC-71, "DTC Logic" | |
| C1130 | ENGINE SIGNAL 1 | BRC-73, "DTC Logic" | |
| C1140 | ACTUATOR RLY | BRC-74, "DTC Logic" | H |
| C1142 | PRESS SEN CIRCUIT | BRC-76, "DTC Logic" | |
| C1143 | ST ANG SEN CIRCUIT | BRC-77, "DTC Logic" | I |
| C1144 | ST ANG SEN SIGNAL | BRC-79, "DTC Logic" | |
| C1145 | YAW RATE SENSOR | BRC-80, "DTC Logic" | |
| C1146 | SIDE G-SEN CIRCUIT | | J |
| C1153 | EMERGENCY BRAKE | BRC-62, "DTC Logic" | |
| C1155 | BR FLUID LEVEL LOW | BRC-81, "DTC Logic" | K |
| C1164 | CV 1 | BRC-83, "DTC Logic" | |
| C1165 | CV 2 | | |
| C1166 | SV 1 | | L |
| C1167 | SV 2 | | |
| C1170 | VARIANT CORDING | BRC-62, "DTC Logic" | M |
| U1000 | CAN COMM CIRCUIT | BRC-85, "DTC Logic" | |
| U1002 | SYSTEM COMM(CAN) | BRC-86, "DTC Logic" | N |

BRAKE CONTROL SYSTEM

[VDC/TCS/ABS]

< WIRING DIAGRAM >

WIRING DIAGRAM

BRAKE CONTROL SYSTEM

Wiring Diagram

INFOID:000000007616468

BRAKE CONTROL SYSTEM

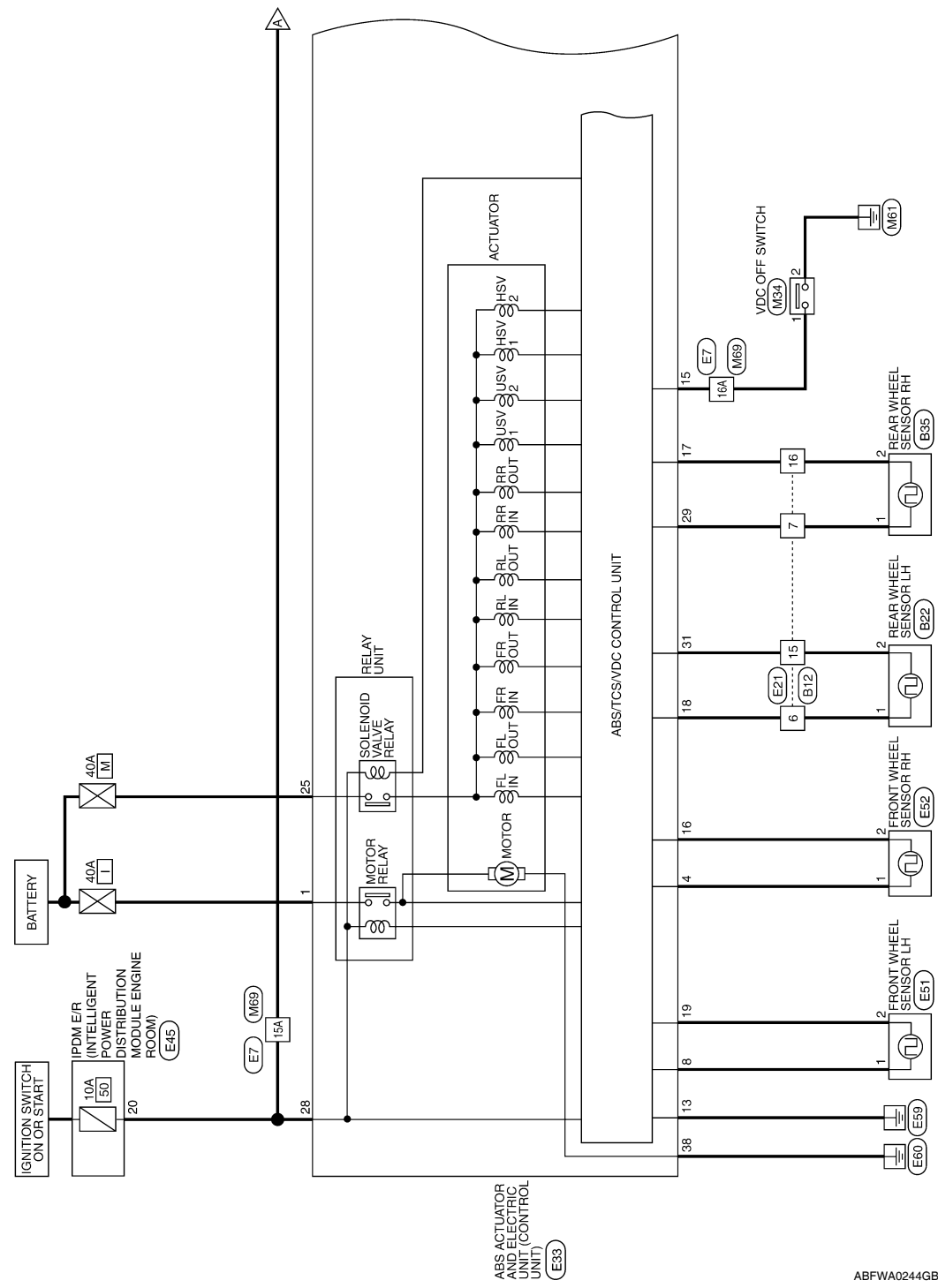

ABFWA0244GB

BRAKE CONTROL SYSTEM

[VDC/TCS/ABS]

< WIRING DIAGRAM >

- ◊ M ◊ : WITH M/T
- ◊ VT ◊ : WITH CVT
- ◊ YA ◊ : WITH TYPE A
- ◊ YB ◊ : WITH TYPE B
- *1 ◊ YA ◊ : 27
- *2 ◊ YB ◊ : 1
- *3 ◊ YA ◊ : 22
- *4 ◊ YB ◊ : 21
- *5 ◊ YA ◊ : 2
- *6 ◊ YB ◊ : 10
- *7 ◊ YA ◊ : 10
- *8 ◊ YB ◊ : 37
- *9 ◊ YA ◊ : 23
- ◊ YB ◊ : 22

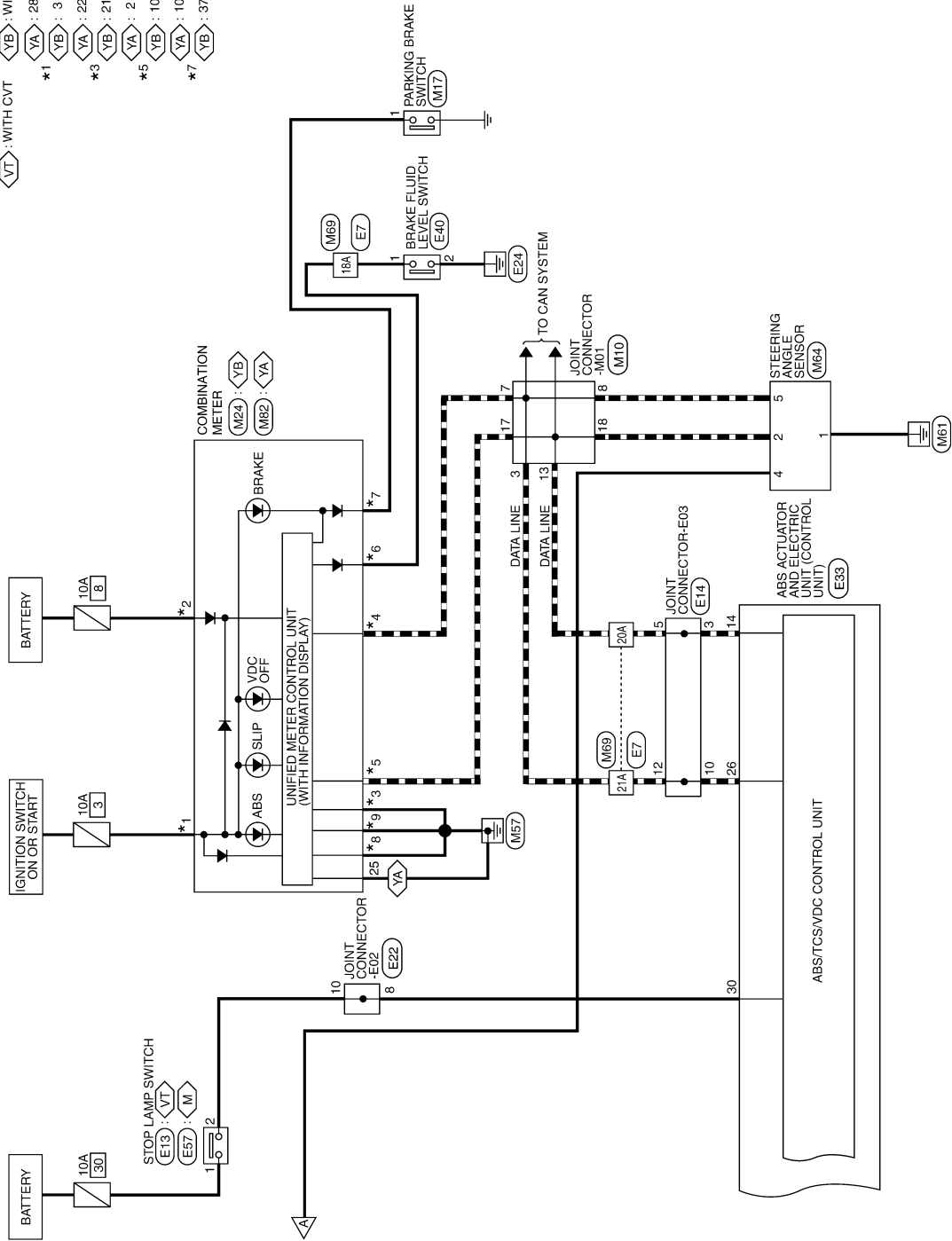

ABFWA0245GB

A
B
C
D
E
BRC
G
H
I
J
K
L
M
N
O
P

BRAKE CONTROL SYSTEM

< WIRING DIAGRAM >

[VDC/TCS/ABS]

BRAKE CONTROL SYSTEM CONNECTORS

| | |
|-----------------|---------------------|
| Connector No. | M10 |
| Connector Name | JOINT CONNECTOR-M01 |
| Connector Color | GRAY |

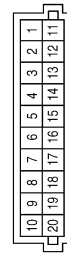

| Terminal No. | Color of Wire | Signal Name |
|--------------|---------------|-------------|
| 3 | L | - |
| 7 | L | - |
| 8 | L | - |
| 13 | P | - |
| 17 | P | - |
| 18 | P | - |

| | |
|-----------------|----------------------|
| Connector No. | M17 |
| Connector Name | PARKING BRAKE SWITCH |
| Connector Color | BLACK |



| Terminal No. | Color of Wire | Signal Name |
|--------------|---------------|-------------|
| 1 | SB | - |

| | |
|-----------------|---------------------------------|
| Connector No. | M24 |
| Connector Name | COMBINATION METER (WITH TYPE B) |
| Connector Color | WHITE |



| Terminal No. | Color of Wire | Signal Name |
|--------------|---------------|---------------|
| 1 | R | BAT |
| 3 | GR | IGN |
| 8 | L | CAN-H |
| 10 | P | CAN-L |
| 21 | B | GND (POWER) |
| 22 | B | GND (CIRCUIT) |
| 23 | B/W | GND (ILL) |
| 36 | LG | BRAKE OIL SW |
| 37 | SB | PKB |

| | |
|-----------------|----------------|
| Connector No. | M34 |
| Connector Name | VDC OFF SWITCH |
| Connector Color | GRAY |

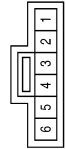

| Terminal No. | Color of Wire | Signal Name |
|--------------|---------------|-------------|
| 1 | SB | - |
| 2 | B | - |

| | |
|-----------------|-----------------------|
| Connector No. | M64 |
| Connector Name | STEERING ANGLE SENSOR |
| Connector Color | WHITE |

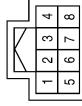

| Terminal No. | Color of Wire | Signal Name |
|--------------|---------------|-------------|
| 1 | B | - |
| 2 | P | CAN-L |
| 4 | GR | - |
| 5 | L | CAN-H |

BRAKE CONTROL SYSTEM

< WIRING DIAGRAM >

[VDC/TCS/ABS]

| | |
|-----------------|------------------------------------|
| Connector No. | M82 |
| Connector Name | COMBINATION METER (WITH TYPE A) |
| Connector Color | WHITE |

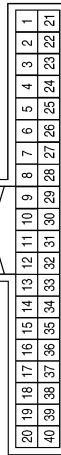

| Terminal No. | Color of Wire | Signal Name |
|--------------|---------------|---------------|
| 1 | L | CAN-H |
| 2 | P | CAN-L |
| 10 | SB | PKB SW |
| 11 | LG | BRAKE OIL SW |
| 21 | B/W | GND (ILL) |
| 22 | B | GND (POWER) |
| 23 | B | GND (CIRCUIT) |
| 25 | B/W | VDC GND |
| 27 | R | BAT |
| 28 | GR | IGN |

| | |
|-----------------|--------------|
| Connector No. | M69 |
| Connector Name | WIRE TO WIRE |
| Connector Color | WHITE |

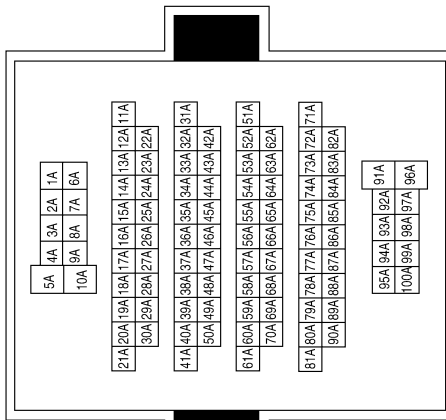

| Terminal No. | Color of Wire | Signal Name |
|--------------|---------------|-------------|
| 15A | GR | - |
| 16A | SB | - |
| 18A | LG | - |
| 20A | P | - |
| 21A | L | - |

A
B
C
D
E
BRC
G
H
I
J
K
L
M
N
O
P

BRAKE CONTROL SYSTEM

< WIRING DIAGRAM >

[VDC/TCS/ABS]

| | |
|-----------------|-----------------------------|
| Connector No. | E13 |
| Connector Name | STOP LAMP SWITCH (WITH CVT) |
| Connector Color | WHITE |



| Terminal No. | Color of Wire | Signal Name |
|--------------|---------------|-------------|
| 1 | SB | - |
| 2 | LG | - |

| Terminal No. | Color of Wire | Signal Name |
|--------------|---------------|-------------|
| 15A | BR | - |
| 16A | R | - |
| 18A | LG | - |
| 20A | P | - |
| 21A | L | - |

| | |
|-----------------|--------------|
| Connector No. | E7 |
| Connector Name | WIRE TO WIRE |
| Connector Color | WHITE |

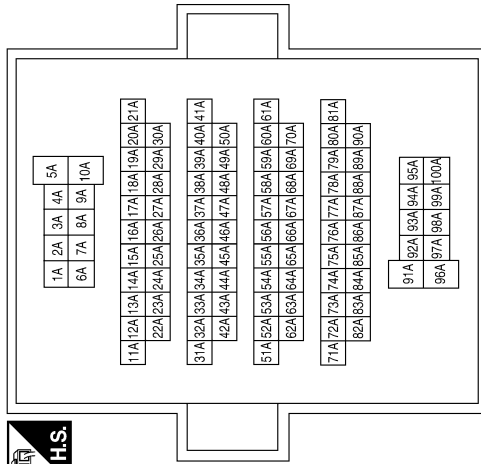

| | |
|-----------------|---------------------|
| Connector No. | E22 |
| Connector Name | JOINT CONNECTOR-E02 |
| Connector Color | WHITE |

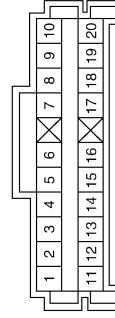

| Terminal No. | Color of Wire | Signal Name |
|--------------|---------------|-------------|
| 8 | LG | - |
| 10 | LG | - |

| | |
|-----------------|--------------|
| Connector No. | E21 |
| Connector Name | WIRE TO WIRE |
| Connector Color | GRAY |



| Terminal No. | Color of Wire | Signal Name |
|--------------|---------------|-------------|
| 6 | R/Y | - |
| 7 | SB | - |
| 15 | W | - |
| 16 | O | - |

| | |
|-----------------|---------------------|
| Connector No. | E14 |
| Connector Name | JOINT CONNECTOR-E03 |
| Connector Color | BLUE |

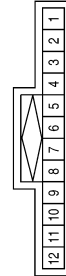

| Terminal No. | Color of Wire | Signal Name |
|--------------|---------------|-------------|
| 3 | P | - |
| 5 | P | - |
| 10 | L | - |
| 12 | L | - |

ABFIA0504GB

BRAKE CONTROL SYSTEM

< WIRING DIAGRAM >

[VDC/TCS/ABS]

| Terminal No. | Color of Wire | Signal Name |
|--------------|---------------|---------------|
| 24 | - | - |
| 25 | W | +B (SOL) |
| 26 | L | CAN-H |
| 27 | - | - |
| 28 | BR | IGN |
| 29 | SB | RR SENSOR SIG |
| 30 | LG | STOP L SIG |
| 31 | W | RL SENSOR VB |
| 32 | - | - |
| 33 | - | - |
| 34 | - | - |
| 35 | - | - |
| 36 | - | - |
| 37 | - | - |
| 38 | B | GND (SOL) |

| Terminal No. | Color of Wire | Signal Name |
|--------------|---------------|---------------|
| 7 | - | - |
| 8 | G | FL SENSOR SIG |
| 9 | - | - |
| 10 | - | - |
| 11 | - | - |
| 12 | - | - |
| 13 | B | GND (MTR) |
| 14 | P | CAN-L |
| 15 | R | VDC OFF SW |
| 16 | Y | FR SENSOR VB |
| 17 | O | RR SENSOR VB |
| 18 | R/Y | RL SENSOR SIG |
| 19 | GR | FL SENSOR VB |
| 20 | - | - |
| 21 | - | - |
| 22 | - | - |
| 23 | - | - |

| | |
|-----------------|---|
| Connector No. | E33 |
| Connector Name | ABS ACTUATOR AND ELECTRIC UNIT (CONTROL UNIT) |
| Connector Color | BLACK |

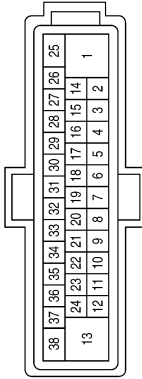

| Terminal No. | Color of Wire | Signal Name |
|--------------|---------------|---------------|
| 1 | Y | +B (MTR) |
| 2 | - | - |
| 3 | - | - |
| 4 | LG | FR SENSOR SIG |
| 5 | - | - |
| 6 | - | - |

| | |
|-----------------|-----------------------|
| Connector No. | E51 |
| Connector Name | FRONT WHEEL SENSOR LH |
| Connector Color | BLACK |



| Terminal No. | Color of Wire | Signal Name |
|--------------|---------------|-------------|
| 1 | G | - |
| 2 | GR | - |

| | |
|-----------------|--|
| Connector No. | E45 |
| Connector Name | IPDM E/R (INTELLIGENT POWER DISTRIBUTION MODULE ENGINE ROOM) |
| Connector Color | BROWN |



| Terminal No. | Color of Wire | Signal Name |
|--------------|---------------|-------------|
| 20 | BR | ABS ECU |

| | |
|-----------------|--------------------------|
| Connector No. | E40 |
| Connector Name | BRAKE FLUID LEVEL SWITCH |
| Connector Color | BLACK |



| Terminal No. | Color of Wire | Signal Name |
|--------------|---------------|-------------|
| 1 | LG | - |
| 2 | B | - |

ABFIA0505GB

A B C D E F G H I J K L M N O P

BRC

BRAKE CONTROL SYSTEM

< WIRING DIAGRAM >

[VDC/TCS/ABS]

| | |
|-----------------|--------------|
| Connector No. | B12 |
| Connector Name | WIRE TO WIRE |
| Connector Color | GRAY |



| | | | | | | | | |
|---|---|----|----|----|----|----|----|----|
| 1 | 2 | 3 | 4 | 5 | 6 | 7 | | |
| 8 | 9 | 10 | 11 | 12 | 13 | 14 | 15 | 16 |

| Terminal No. | Color of Wire | Signal Name |
|--------------|---------------|-------------|
| 6 | V | - |
| 7 | SB | - |
| 15 | W | - |
| 16 | O | - |

| | |
|-----------------|-----------------------------|
| Connector No. | E57 |
| Connector Name | STOP LAMP SWITCH (WITH M/T) |
| Connector Color | BLACK |



| | |
|---|---|
| 2 | 1 |
|---|---|

| Terminal No. | Color of Wire | Signal Name |
|--------------|---------------|-------------|
| 1 | SB | - |
| 2 | LG | - |

| | |
|-----------------|-----------------------|
| Connector No. | E52 |
| Connector Name | FRONT WHEEL SENSOR RH |
| Connector Color | BLACK |



| | |
|---|---|
| 1 | 2 |
|---|---|

| Terminal No. | Color of Wire | Signal Name |
|--------------|---------------|-------------|
| 1 | LG | - |
| 2 | Y | - |

| | |
|-----------------|----------------------|
| Connector No. | B35 |
| Connector Name | REAR WHEEL SENSOR RH |
| Connector Color | BLACK |



| | |
|---|---|
| 1 | 2 |
|---|---|

| Terminal No. | Color of Wire | Signal Name |
|--------------|---------------|-------------|
| 1 | SB | - |
| 2 | O | - |

| | |
|-----------------|----------------------|
| Connector No. | B22 |
| Connector Name | REAR WHEEL SENSOR LH |
| Connector Color | GRAY |



| | |
|---|---|
| 1 | 2 |
|---|---|

| Terminal No. | Color of Wire | Signal Name |
|--------------|---------------|-------------|
| 1 | V | - |
| 2 | W | - |

ABFIA0506GB

BASIC INSPECTION

DIAGNOSIS AND REPAIR WORK FLOW

Work Flow

INFOID:000000007616469

OVERALL SEQUENCE

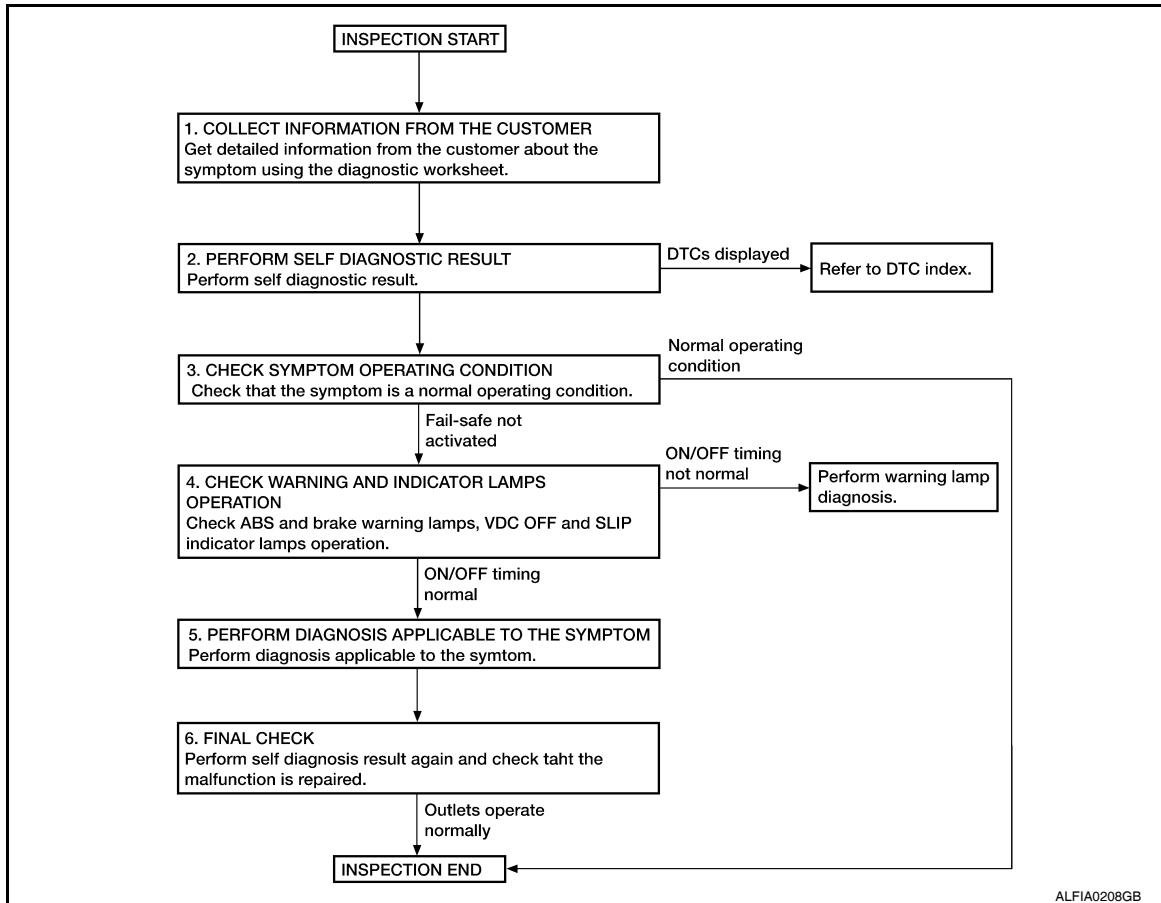

DETAILED FLOW

1. COLLECT INFORMATION FROM THE CUSTOMER

Get detailed information from the customer about the symptom (the condition and the environment when the incident/malfunction occurred) using the diagnostic worksheet. Refer to [BRC-52, "Diagnostic Work Sheet"](#).

>> GO TO 2.

2. PERFORM SELF DIAGNOSTIC RESULT

Perform self diagnostic result. Refer to [BRC-32, "CONSULT Function \(ABS\)"](#).

Are any DTCs displayed?

YES >> Refer to [BRC-42, "DTC Index"](#).

NO >> GO TO 3.

3. CHECK SYMPTOM OPERATING CONDITION

Check that the symptom is a normal operating condition. Refer to [BRC-102, "Description"](#).

Is the symptom a normal operating condition?

YES >> Inspection End.

NO >> GO TO 4.

4. CHECK WARNING AND INDICATOR LAMPS OPERATION

DIAGNOSIS AND REPAIR WORK FLOW

< BASIC INSPECTION >

[VDC/TCS/ABS]

Check ABS and brake warning lamps, and VDC OFF and SLIP indicator lamps operation. Refer to [MWI-9, "METER SYSTEM : System Description"](#) (type A) or [MWI-59, "METER SYSTEM : System Description"](#) (type B).

Is ON/OFF timing normal?

YES >> GO TO 5.

NO >> Perform warning lamp diagnosis. Refer to [BRC-91, "Component Function Check"](#) (ABS warning lamp), [BRC-92, "Component Function Check"](#) (brake warning lamp), [BRC-93, "Component Function Check"](#) (VDC OFF indicator lamp) or [BRC-94, "Component Function Check"](#) (SLIP indicator lamp).

5. PERFORM DIAGNOSIS APPLICABLE TO THE SYMPTOM

Perform diagnosis applicable to the symptom. Refer to [BRC-95, "Symptom Table"](#).

>> GO TO 6.

6. FINAL CHECK

Perform self diagnostic result again, and check that the malfunction is repaired. After checking, erase the self diagnosis memory. Refer to [BRC-32, "CONSULT Function \(ABS\)"](#).

>> Inspection End.

Diagnostic Work Sheet

INFOID:000000007616470

| | | | |
|---------------------------|---|---|--|
| Customer name MR/MS | Model & Year | VIN | |
| Engine # | Trans. | Mileage | |
| Incident Date | Manuf. Date | In Service Date | |
| Symptoms | <input type="checkbox"/> Noise and vibration (from engine compartment) <input type="checkbox"/> Noise and vibration (from axle) | <input type="checkbox"/> Warning / Indicator activate | <input type="checkbox"/> Firm pedal operation <input type="checkbox"/> Large stroke pedal operation |
| | <input type="checkbox"/> TCS does not work (Rear wheels slip when accelerating) | <input type="checkbox"/> ABS does not work (Wheels lock when braking) | <input type="checkbox"/> Lack of sense of acceleration |
| Engine conditions | <input type="checkbox"/> When starting <input type="checkbox"/> After starting | | |
| Road conditions | <input type="checkbox"/> Low friction road (<input type="checkbox"/> Snow <input type="checkbox"/> Gravel <input type="checkbox"/> Other) <input type="checkbox"/> Bumps / potholes | | |
| Driving conditions | <input type="checkbox"/> Full-acceleration <input type="checkbox"/> High speed cornering <input type="checkbox"/> Vehicle speed: Greater than 10 km/h (6 MPH) <input type="checkbox"/> Vehicle speed: 10 km/h (6 MPH) or less <input type="checkbox"/> Vehicle is stopped | | |
| Applying brake conditions | <input type="checkbox"/> Suddenly <input type="checkbox"/> Gradually | | |
| Other conditions | <input type="checkbox"/> Operation of electrical equipment <input type="checkbox"/> Shift change <input type="checkbox"/> Other descriptions | | |

SFIA3265E

ADDITIONAL SERVICE WHEN REPLACING ABS ACTUATOR AND ELECTRIC UNIT (CONTROL UNIT)

< BASIC INSPECTION >

[VDC/TCS/ABS]

ADDITIONAL SERVICE WHEN REPLACING ABS ACTUATOR AND ELECTRIC UNIT (CONTROL UNIT)

Description

INFOID:000000007616471

After replacing the ABS actuator and electric unit (control unit), perform the neutral position adjustment for the steering angle sensor. Refer to [BRC-54, "Work Procedure"](#).

Work Procedure

INFOID:000000007641919

1. PERFORM THE NEUTRAL POSITION ADJUSTMENT FOR THE STEERING ANGLE SENSOR

Perform the neutral position adjustment for the steering angle sensor.

>> Refer to [BRC-54, "Work Procedure"](#).

A
B
C
D
E
G
H
I
J
K
L
M
N
O
P

BRC

ADJUSTMENT OF STEERING ANGLE SENSOR NEUTRAL POSITION

< BASIC INSPECTION >

[VDC/TCS/ABS]

ADJUSTMENT OF STEERING ANGLE SENSOR NEUTRAL POSITION

Description

INFOID:000000007616472

Refer to the table below to determine if adjustment of steering angle sensor neutral position is required.

×: Required –: Not required

| Situation | Adjustment of steering angle sensor neutral position |
|---|--|
| Removing/Installing ABS actuator and electric unit (control unit) | — |
| Replacing ABS actuator and electric unit (control unit) | × |
| Removing/Installing steering angle sensor | × |
| Replacing steering angle sensor | × |
| Removing/Installing steering components | × |
| Replacing steering components | × |
| Removing/Installing suspension components | × |
| Replacing suspension components | × |
| Change tires to new ones | — |
| Tire rotation | — |
| Adjusting wheel alignment | × |

Work Procedure

INFOID:000000007616473

ADJUSTMENT OF STEERING ANGLE SENSOR NEUTRAL POSITION

CAUTION:

**To adjust neutral position of steering angle sensor, make sure to use CONSULT.
(Adjustment cannot be done without CONSULT).**

1. ALIGN THE VEHICLE STATUS

Stop vehicle with front wheels in straight-ahead position.

>> GO TO 2

2. PERFORM THE NEUTRAL POSITION ADJUSTMENT FOR THE STEERING ANGLE SENSOR

1. On the CONSULT screen, touch "WORK SUPPORT" and "ST ANG SEN ADJUSTMENT" in order.
2. Touch "START".

CAUTION:

Do not touch steering wheel while adjusting steering angle sensor.

3. After approximately 10 seconds, touch "END".

NOTE:

After approximately 60 seconds, it ends automatically.

4. Turn ignition switch OFF, then turn it ON again.

CAUTION:

Be sure to perform above operation.

>> GO TO 3

3. CHECK DATA MONITOR

1. Run vehicle with front wheels in straight-ahead position, then stop.
2. Select "DATA MONITOR". Then make sure "STR ANGLE SIG" is within $0 \pm 2.5^\circ$.

Is the steering angle within the specified range?

YES >> GO TO 4

NO >> Perform the neutral position adjustment for the steering angle sensor again, GO TO 1

4. ERASE THE SELF-DIAGNOSIS MEMORY

Erase the self-diagnosis memory of the ABS actuator and electric unit (control unit) and ECM.

- ABS actuator and electric unit (control unit): Refer to [BRC-32, "CONSULT Function \(ABS\)"](#).

ADJUSTMENT OF STEERING ANGLE SENSOR NEUTRAL POSITION

< BASIC INSPECTION >

[VDC/TCS/ABS]

- ECM: Refer to [EC-59. "CONSULT Function"](#).

Are the memories erased?

YES >> Inspection End

NO >> Check the items indicated by the self-diagnosis.

A

B

C

D

E

BRC

G

H

I

J

K

L

M

N

O

P

C1101, C1102, C1103, C1104 WHEEL SENSOR

< DTC/CIRCUIT DIAGNOSIS >

[VDC/TCS/ABS]

DTC/CIRCUIT DIAGNOSIS

C1101, C1102, C1103, C1104 WHEEL SENSOR

DTC Logic

INFOID:000000007641984

DTC DETECTION LOGIC

| DTC | Display Item | Malfunction detected condition | Possible causes |
|-------|----------------|--|---|
| C1101 | RR RH SENSOR-1 | When an open circuit is detected in rear wheel sensor RH circuit. | <ul style="list-style-type: none">• Harness or connector• Wheel sensor• ABS actuator and electric unit (control unit) |
| C1102 | RR LH SENSOR-1 | When an open circuit is detected in rear wheel sensor LH circuit. | |
| C1103 | FR RH SENSOR-1 | When an open circuit is detected in front wheel sensor RH circuit. | |
| C1104 | FR LH SENSOR-1 | When an open circuit is detected in front wheel sensor LH circuit. | |

DTC CONFIRMATION PROCEDURE

1. CHECK SELF DIAGNOSTIC RESULT

Ⓜ With CONSULT.

1. Start engine and drive vehicle at approximately 30 km/h (19 MPH) or more for approximately 1 minute.
2. Perform self diagnostic result.

Is DTC C1101, C1102, C1103 or C1104 detected?

- YES >> Proceed to diagnosis procedure. Refer to [BRC-56, "Diagnosis Procedure"](#).
NO >> Inspection End.

Diagnosis Procedure

INFOID:000000007641985

Regarding Wiring Diagram information, refer to [BRC-44, "Wiring Diagram"](#).

CAUTION:

Do not check between wheel sensor terminals.

1. CONNECTOR INSPECTION

1. Disconnect ABS actuator and electric unit (control unit) connector E33 and wheel sensor connector of wheel with DTC.
2. Check connectors and terminals for deformation, disconnection, looseness or damage.

Is the inspection result normal?

- YES >> GO TO 2
NO >> Repair or replace as necessary.

2. CHECK WHEEL SENSOR OUTPUT SIGNAL

1. Connect ABS active wheel sensor tester (J-45741) to wheel sensor using appropriate adapter.
2. Turn on the ABS active wheel sensor tester power switch.

NOTE:

The green POWER indicator should illuminate. If the POWER indicator does not illuminate, replace the battery in the ABS active wheel sensor tester before proceeding.

3. Spin the wheel of the vehicle by hand and observe the red SENSOR indicator on the ABS active wheel sensor tester. The red SENSOR indicator should flash on and off to indicate an output signal.

NOTE:

If the red SENSOR indicator illuminates but does not flash, reverse the polarity of the tester leads and retest.

Does the ABS active wheel sensor tester detect a signal?

- YES >> GO TO 3

C1101, C1102, C1103, C1104 WHEEL SENSOR

< DTC/CIRCUIT DIAGNOSIS >

[VDC/TCS/ABS]

NO >> Replace the wheel sensor. Refer to [BRC-103. "FRONT WHEEL SENSOR : Removal and Installation"](#) (front) or [BRC-104. "REAR WHEEL SENSOR : Removal and Installation"](#) (rear).

3. CHECK WIRING HARNESS FOR OPEN CIRCUIT

Check continuity between ABS actuator and electric unit (control unit) connector E33 and wheel sensor connector of wheel with DTC.

| Wheel sensor | ABS actuator and electric unit (control unit) | | Wheel sensor | | Continuity |
|--------------|---|----------|--------------|----------|------------|
| | Connector | Terminal | Connector | Terminal | |
| Front LH | E33 | 8 | E51 | 1 | Yes |
| | | 19 | | 2 | |
| Front RH | | 4 | E52 | 1 | |
| | | 16 | | 2 | |
| Rear LH | | 18 | B22 | 1 | |
| | | 31 | | 2 | |
| Rear RH | | 29 | B35 | 1 | |
| | | 17 | | 2 | |

Is the inspection result normal?

YES >> Replace the ABS actuator and electric unit (control unit). Refer to [BRC-107. "Removal and Installation"](#).

NO >> Repair the circuit.

A
B
C
D
E
G
H
I
J
K
L
M
N
O
P

BRC

C1105, C1106, C1107, C1108 WHEEL SENSOR

< DTC/CIRCUIT DIAGNOSIS >

[VDC/TCS/ABS]

C1105, C1106, C1107, C1108 WHEEL SENSOR

DTC Logic

INFOID:000000007641986

DTC DETECTION LOGIC

| DTC | Display Item | Malfunction detected condition | Possible causes |
|-------|----------------|---|--|
| C1105 | RR RH SENSOR-2 | <ul style="list-style-type: none">When power supply voltage of rear wheel sensor RH is low.When distance between rear wheel sensor RH and rear wheel sensor RH rotor is large.When installation of rear wheel sensor RH or rear wheel sensor RH rotor is not normal. | <ul style="list-style-type: none">Harness or connectorWheel sensorABS actuator and electric unit (control unit)Sensor rotor |
| C1106 | RR LH SENSOR-2 | <ul style="list-style-type: none">When power supply voltage of rear wheel sensor-LH is low.When distance between rear wheel sensor LH and rear wheel sensor LH rotor is large.When installation of rear wheel sensor LH or rear wheel sensor LH rotor is not normal. | |
| C1107 | FR RH SENSOR-2 | <ul style="list-style-type: none">When power supply voltage of front wheel sensor RH is low.When distance between front wheel sensor RH and front wheel sensor RH rotor is large.When installation of front wheel sensor RH or front wheel sensor RH rotor is not normal. | |
| C1108 | FR LH SENSOR-2 | <ul style="list-style-type: none">When power supply voltage of front wheel sensor LH is low.When distance between front wheel sensor LH and front wheel sensor LH rotor is large.When installation of front wheel sensor LH or front wheel sensor LH rotor is not normal. | |

DTC CONFIRMATION PROCEDURE

1. CHECK SELF DIAGNOSTIC RESULT

Ⓐ With CONSULT.

- Start engine and drive vehicle at approximately 30 km/h (19 MPH) or more for approximately 1 minute.
- Perform self diagnostic result.

Is DTC C1105, C1106, C1107 or C1108 detected?

- YES >> Proceed to diagnosis procedure. Refer to [BRC-58, "Diagnosis Procedure"](#).
NO >> Inspection End.

Diagnosis Procedure

INFOID:000000007641987

Regarding Wiring Diagram information, refer to [BRC-44, "Wiring Diagram"](#).

CAUTION:

Do not check between wheel sensor terminals.

1. CONNECTOR INSPECTION

- Disconnect ABS actuator and electric unit (control unit) connector E33 and wheel sensor connector of wheel with DTC.
- Check terminals for deformation, disconnection, looseness or damage.

Is the inspection result normal?

- YES >> GO TO 2
NO >> Repair or replace as necessary.

2. CHECK WHEEL SENSOR OUTPUT SIGNAL

C1105, C1106, C1107, C1108 WHEEL SENSOR

[VDC/TCS/ABS]

< DTC/CIRCUIT DIAGNOSIS >

1. Connect ABS active wheel sensor tester (J-45741) to wheel sensor using appropriate adapter.
2. Turn on the ABS active wheel sensor tester power switch.

NOTE:

The green POWER indicator should illuminate. If the POWER indicator does not illuminate, replace the battery in the ABS active wheel sensor tester before proceeding.

3. Spin the wheel of the vehicle by hand and observe the red SENSOR indicator on the ABS active wheel sensor tester. The red SENSOR indicator should flash on and off to indicate an output signal.

NOTE:

If the red SENSOR indicator illuminates but does not flash, reverse the polarity of the tester leads and retest.

Does the ABS active wheel sensor tester detect a signal?

YES >> GO TO 3

NO >> Replace the wheel sensor. Refer to [BRC-103, "FRONT WHEEL SENSOR : Removal and Installation"](#) (front) or [BRC-104, "REAR WHEEL SENSOR : Removal and Installation"](#) (rear).

3.CHECK WHEEL BEARINGS

Check wheel bearing axial end play. Refer to [FAX-7, "Inspection"](#) (front) or [RAX-5, "Inspection"](#) (rear).

Is the inspection result normal?

YES >> GO TO 4

NO >> Repair or replace as necessary. Refer to [FAX-9, "Removal and Installation"](#) (front) or [RAX-6, "Removal and Installation"](#) (rear).

4.CHECK WIRING HARNESS FOR SHORT CIRCUIT

Check continuity between wheel sensor connector terminals and ground of wheel with DTC.

| Wheel Sensor | | | Ground | Continuity |
|--------------|-----------|----------|--------|------------|
| Wheel | Connector | Terminal | | |
| Front LH | E51 | 1 | — | No |
| | | 2 | | |
| Front RH | E52 | 1 | | |
| | | 2 | | |
| Rear LH | B22 | 1 | | |
| | | 2 | | |
| Rear RH | B35 | 1 | | |
| | | 2 | | |

Is the inspection result normal?

YES >> Replace the ABS actuator and electric unit (control unit). Refer to [BRC-107, "Removal and Installation"](#).

NO >> Repair the circuit.

C1109 POWER AND GROUND SYSTEM

< DTC/CIRCUIT DIAGNOSIS >

[VDC/TCS/ABS]

C1109 POWER AND GROUND SYSTEM

DTC Logic

INFOID:000000007641988

DTC DETECTION LOGIC

| DTC | Display Item | Malfunction detected condition | Possible causes |
|-------|-------------------------------|---|--|
| C1109 | BATTERY VOLTAGE [ABNORMAL] | <ul style="list-style-type: none">• When ignition voltage is 10 V or less.• When ignition voltage is 16 V or more. | <ul style="list-style-type: none">• Harness or connector• ABS actuator and electric unit (control unit)• Fuse• Ignition power supply system• Battery |

DTC CONFIRMATION PROCEDURE

1. CHECK SELF DIAGNOSTIC RESULT

④ With CONSULT.

1. Turn the ignition switch ON.
2. Perform self diagnostic result.

Is DTC C1109 detected?

- YES >> Proceed to diagnosis procedure. Refer to [BRC-60, "Diagnosis Procedure"](#).
NO >> Inspection End.

Diagnosis Procedure

INFOID:000000007641989

Regarding Wiring Diagram information, refer to [BRC-44, "Wiring Diagram"](#).

1. CONNECTOR INSPECTION

1. Turn ignition switch OFF.
2. Disconnect ABS actuator and electric unit (control unit) connectors.
3. Check connectors and terminals for deformation, disconnection, looseness or damage.

Is the inspection result normal?

- YES >> GO TO 2
NO >> Repair or replace as necessary.

2. CHECK ABS ACTUATOR AND ELECTRIC UNIT (CONTROL UNIT) IGNITION POWER SUPPLY CIRCUIT

Check voltage between ABS actuator and electric unit (control unit) connector E33 terminal 28 and ground.

| ABS actuator and electric unit (control unit) | | Ground | Condition | Voltage |
|---|----------|--------|---------------------|-----------------|
| Connector | Terminal | | | |
| E33 | 28 | — | Ignition switch ON | Battery voltage |
| | | | Ignition switch OFF | 0V |

Is the inspection result normal?

- YES >> GO TO 3
NO >> Repair or replace malfunctioning components.

3. CHECK ABS ACTUATOR AND ELECTRIC UNIT (CONTROL UNIT) GROUND CIRCUIT

1. Turn ignition switch OFF.
2. Check continuity between ABS actuator and electric unit (control unit) connector E33 terminals 13, 38 and ground.

C1109 POWER AND GROUND SYSTEM

< DTC/CIRCUIT DIAGNOSIS >

[VDC/TCS/ABS]

| ABS actuator and electric unit (control unit) | | — | Continuity |
|---|----------|--------|------------|
| Connector | Terminal | | |
| E33 | 13 | Ground | Yes |
| | 38 | | |

Is the inspection result normal?

- YES >> Replace ABS actuator and electric unit (control unit). Refer to [BRC-107, "Removal and Installation"](#).
- NO >> Repair or replace malfunctioning components.

A
B
C
D
E
G
H
I
J
K
L
M
N
O
P

BRC

C1110, C1153, C1170 ABS ACTUATOR AND ELECTRIC UNIT (CONTROL UNIT)
 < DTC/CIRCUIT DIAGNOSIS > [VDC/TCS/ABS]

C1110, C1153, C1170 ABS ACTUATOR AND ELECTRIC UNIT (CONTROL UNIT)

DTC Logic

INFOID:000000007642044

DTC DETECTION LOGIC

| DTC | Display item | Malfunction detected condition | Possible cause |
|-------|--------------------|---|---|
| C1110 | CONTROLLER FAILURE | When there is an internal malfunction in the ABS actuator and electric unit (control unit). | • ABS actuator and electric unit (control unit) |
| C1153 | EMERGENCY BRAKE | When ABS actuator and electric unit (control unit) is malfunctioning. (Pressure increase is too much or too little) | |
| C1170 | VARIANT CODING | In a case where VARIANT CODING is different. | |

DTC CONFIRMATION PROCEDURE

1. CHECK SELF-DIAGNOSIS RESULTS

Check the self-diagnosis results.

| |
|------------------------|
| Self-diagnosis results |
| CONTROLLER FAILURE |
| EMERGENCY BRAKE |
| VARIANT CODING |

Is above displayed on the self-diagnosis display?

- YES >> Proceed to diagnosis procedure. Refer to [BRC-62, "Diagnosis Procedure"](#).
 NO >> Inspection End.

Diagnosis Procedure

INFOID:000000007642045

1. REPLACE ABS ACTUATOR AND ELECTRIC UNIT (CONTROL UNIT)

CAUTION:

Replace ABS actuator and electric unit (control unit) when self diagnostic result shows items other than those applicable.

- >> Replace ABS actuator and electric unit (control unit). Refer to [BRC-107, "Removal and Installation"](#).

C1111 PUMP MOTOR

< DTC/CIRCUIT DIAGNOSIS >

[VDC/TCS/ABS]

C1111 PUMP MOTOR

DTC Logic

INFOID:000000007641990

DTC DETECTION LOGIC

| DTC | Display Item | Malfunction detected condition | Possible causes |
|-------|--------------|--|--|
| C1111 | PUMP MOTOR | <ul style="list-style-type: none"> When a malfunction is detected in motor or motor relay. When a low pressure malfunction is detected in accumulator. When a malfunction is detected in accumulator pressure sensor. | <ul style="list-style-type: none"> Harness or connector ABS actuator and electric unit (control unit) Fusible link Battery power supply system Motor/accumulator assembly |

DTC CONFIRMATION PROCEDURE

1. CHECK SELF DIAGNOSTIC RESULT

Ⓜ With CONSULT.

- Turn ignition switch OFF.
- Depress brake pedal 20 times or more.
- Start the engine and wait for 3 minutes or more.
- Perform self diagnostic result.

Is DTC C1111 detected?

- YES >> Proceed to diagnosis procedure. Refer to [BRC-63, "Diagnosis Procedure"](#).
 NO >> Inspection End.

Diagnosis Procedure

INFOID:000000007641991

Regarding Wiring Diagram information, refer to [BRC-44, "Wiring Diagram"](#).

1. CONNECTOR INSPECTION

- Turn ignition switch OFF.
- Disconnect ABS actuator and electric unit (control unit) connectors.
- Check connectors and terminals for deformation, disconnection, looseness or damage.

Is the inspection result normal?

- YES >> GO TO 2
 NO >> Repair or replace as necessary.

2. CHECK ABS MOTOR AND MOTOR RELAY BATTERY POWER SUPPLY

Check voltage between ABS actuator and electric unit (control unit) connector E33 terminal 1 and ground.

| ABS actuator and electric unit (control unit) | | — | Voltage |
|---|----------|--------|-----------------|
| Connector | Terminal | | |
| E33 | 1 | Ground | Battery voltage |

Is the inspection result normal?

- YES >> GO TO 3.
 NO >> Repair or replace malfunctioning components.

3. CHECK ABS ACTUATOR AND ELECTRIC UNIT (CONTROL UNIT) GROUND CIRCUIT

Check continuity between ABS actuator and electric unit (control unit) connector E33 terminals 13, 38 and ground.

C1111 PUMP MOTOR

< DTC/CIRCUIT DIAGNOSIS >

[VDC/TCS/ABS]

| ABS actuator and electric unit (control unit) | | — | Continuity |
|---|----------|--------|------------|
| Connector | Terminal | | |
| E33 | 13 | Ground | Yes |
| | 38 | | |

Is the inspection result normal?

- YES >> Replace ABS actuator and electric unit (control unit). Refer to [BRC-107, "Removal and Installation"](#).
- NO >> Repair or replace malfunctioning components.

C1115 ABS SENSOR [ABNORMAL SIGNAL]

< DTC/CIRCUIT DIAGNOSIS >

[VDC/TCS/ABS]

C1115 ABS SENSOR [ABNORMAL SIGNAL]

DTC Logic

INFOID:000000007641992

DTC DETECTION LOGIC

| DTC | Display Item | Malfunction detected condition | Possible causes |
|-------|------------------------------|---|--|
| C1115 | ABS SENSOR [ABNORMAL SIGNAL] | When difference in wheel speed between any wheel and others is detected while the vehicle is driven, because of installation of tires other than specified. | <ul style="list-style-type: none">• Harness or connector• Wheel sensor• Sensor rotor• ABS actuator and electric unit (control unit) |

DTC CONFIRMATION PROCEDURE

1. CHECK SELF DIAGNOSTIC RESULT

Ⓜ With CONSULT.

1. Start engine and drive vehicle at approximately 30 km/h (19 MPH) or more for approximately 1 minute.
2. Perform self diagnostic result.

Is DTC C1115 detected?

- YES >> Proceed to diagnosis procedure. Refer to [BRC-65, "Diagnosis Procedure"](#).
NO >> Inspection End.

Diagnosis Procedure

INFOID:000000007641993

Regarding Wiring Diagram information, refer to [BRC-44, "Wiring Diagram"](#).

CAUTION:

Do not check between wheel sensor terminals.

1. CONNECTOR INSPECTION

1. Disconnect ABS actuator and electric unit (control unit) connector E33 and wheel sensor connector of wheel with DTC.
2. Check terminals for deformation, disconnection, looseness or damage.

Is the inspection result normal?

- YES >> GO TO 2
NO >> Repair or replace as necessary.

2. CHECK WHEEL SENSOR OUTPUT SIGNAL

1. Connect ABS active wheel sensor tester (J-45741) to wheel sensor using appropriate adapter.
2. Turn on the ABS active wheel sensor tester power switch.

NOTE:

The green POWER indicator should illuminate. If the POWER indicator does not illuminate, replace the battery in the ABS active wheel sensor tester before proceeding.

3. Spin the wheel of the vehicle by hand and observe the red SENSOR indicator on the ABS active wheel sensor tester. The red SENSOR indicator should flash on and off to indicate an output signal.

NOTE:

If the red SENSOR indicator illuminates but does not flash, reverse the polarity of the tester leads and retest.

Does the ABS active wheel sensor tester detect a signal?

- YES >> GO TO 3
NO >> Replace the wheel sensor. Refer to [BRC-103, "FRONT WHEEL SENSOR : Removal and Installation"](#) (front) or [BRC-104, "REAR WHEEL SENSOR : Removal and Installation"](#) (rear).

3. CHECK TIRES

Check the inflation pressure, wear and size of each tire.

Is the inspection result normal?

C1115 ABS SENSOR [ABNORMAL SIGNAL]

[VDC/TCS/ABS]

< DTC/CIRCUIT DIAGNOSIS >

YES >> GO TO 4

NO >> Adjust tire pressure, or replace tire(s).

4.CHECK WIRING HARNESS FOR SHORT CIRCUIT

Check continuity between wheel sensor connector terminals and ground of wheel with DTC.

| Wheel Sensor | | | Ground | Continuity |
|--------------|-----------|----------|--------|------------|
| Wheel | Connector | Terminal | | |
| Front LH | E51 | 1 | — | No |
| | | 2 | | |
| Front RH | E52 | 1 | | |
| | | 2 | | |
| Rear LH | B22 | 1 | | |
| | | 2 | | |
| Rear RH | B35 | 1 | | |
| | | 2 | | |

Is the inspection result normal?

YES >> GO TO 5

NO >> Repair the circuit.

5.CHECK WIRING HARNESS FOR OPEN CIRCUIT

Check continuity between ABS actuator and electric unit (control unit) connector E33 and wheel sensor connector of wheel with DTC.

| Wheel sensor | ABS actuator and electric unit (control unit) | | Wheel sensor | | Continuity |
|--------------|---|----------|--------------|----------|------------|
| | Connector | Terminal | Connector | Terminal | |
| Front LH | E33 | 8 | E51 | 1 | Yes |
| | | 19 | | 2 | |
| Front RH | | 4 | E52 | 1 | |
| | | 16 | | 2 | |
| Rear LH | | 18 | B22 | 1 | |
| | | 31 | | 2 | |
| Rear RH | | 29 | B35 | 1 | |
| | | 17 | | 2 | |

Is the inspection result normal?

YES >> Replace the ABS actuator and electric unit (control unit). Refer to [BRC-107, "Removal and Installation"](#).

NO >> Repair the circuit.

C1116 STOP LAMP SWITCH

< DTC/CIRCUIT DIAGNOSIS >

[VDC/TCS/ABS]

C1116 STOP LAMP SWITCH

DTC Logic

INFOID:000000007642046

DTC DETECTION LOGIC

| DTC | Display item | Malfunction detected condition | Possible cause |
|-------|--------------|--|---|
| C1116 | STOP LAMP SW | When stop lamp switch circuit is open. | <ul style="list-style-type: none">• Harness or connector• Stop lamp switch• ABS actuator and electric unit (control unit) |

DTC CONFIRMATION PROCEDURE

1. CHECK SELF-DIAGNOSIS RESULTS

Check the self-diagnosis results.

| Self-diagnosis results |
|------------------------|
| STOP LAMP SW |

Is above displayed on the self-diagnosis display?

YES >> Proceed to diagnosis procedure. Refer to [BRC-67, "Diagnosis Procedure"](#).

NO >> Inspection End.

Diagnosis Procedure

INFOID:000000007642047

Regarding Wiring Diagram information, refer to [BRC-44, "Wiring Diagram"](#).

1. CONNECTOR INSPECTION

1. Disconnect stop lamp switch connector and ABS actuator and electric unit (control unit) connector.
2. Check terminals for deformation, disconnection, looseness or damage.

Is the inspection result normal?

YES >> GO TO 2

NO >> Repair or replace as necessary.

2. CHECK STOP LAMP SWITCH CIRCUIT

1. Connect stop lamp switch connector.
2. Check voltage between ABS actuator and electric unit (control unit) connector E33 terminal 30 and ground.

| ABS actuator and electric unit (control unit) | | Ground | Condition | Voltage (Approx.) |
|---|----------|--------|-----------------------|-------------------|
| Connector | Terminal | | | |
| E33 | 30 | — | Brake pedal depressed | Battery voltage |
| | | | Brake pedal released | 0V |

Is the inspection result normal?

YES >> Replace ABS actuator and electric unit (control unit). Refer to [BRC-107, "Removal and Installation"](#).

NO >> GO TO 3

3. CHECK STOP LAMP SWITCH CIRCUIT FOR OPEN

1. Disconnect stop lamp switch connector.
2. Check continuity between ABS actuator and electric unit (control unit) connector E33 terminal 30 and stop lamp switch connector E13 (with CVT) or E57 (with M/T) terminal 2.

C1116 STOP LAMP SWITCH

< DTC/CIRCUIT DIAGNOSIS >

[VDC/TCS/ABS]

| ABS actuator and electric unit (control unit) | | Stop lamp switch | | Continuity |
|---|----------|------------------|----------|------------|
| Connector | Terminal | Connector | Terminal | |
| E33 | 30 | E13 (with CVT) | 2 | Yes |
| | | E57 (with M/T) | | |

Is the inspection result normal?

YES >> GO TO 4.

NO >> Repair or replace as necessary.

4. CHECK STOP LAMP SWITCH CIRCUIT FOR SHORT

Check continuity between ABS actuator and electric unit (control unit) connector E33 terminal 30 and ground.

| ABS actuator and electric unit (control unit) | | Ground | Continuity |
|---|----------|--------|------------|
| Connector | Terminal | | |
| E33 | 30 | — | No |

Is the inspection result normal?

YES >> Replace stop lamp switch.

NO >> Repair harness or connectors.

C1120, C1122, C1124, C1126 ABS IN VALVE SYSTEM

< DTC/CIRCUIT DIAGNOSIS >

[VDC/TCS/ABS]

C1120, C1122, C1124, C1126 ABS IN VALVE SYSTEM

DTC Logic

INFOID:000000007641998

DTC DETECTION LOGIC

| DTC | Display Item | Malfunction detected condition | Possible causes |
|-------|------------------|--|---|
| C1120 | FR LH IN ABS SOL | When a malfunction is detected in front LH ABS IN valve. | <ul style="list-style-type: none">• Harness or connector• ABS actuator and electric unit (control unit)• Fusible link• Battery power supply system |
| C1122 | FR RH IN ABS SOL | When a malfunction is detected in front RH ABS IN valve. | |
| C1124 | RR LH IN ABS SOL | When a malfunction is detected in rear LH ABS IN valve. | |
| C1126 | RR RH IN ABS SOL | When a malfunction is detected in rear RH ABS IN valve. | |

DTC CONFIRMATION PROCEDURE

1. CHECK SELF DIAGNOSTIC RESULT

④ With CONSULT.

1. Turn ignition switch ON.
2. Perform self diagnostic result.

Is DTC C1120, C1122, C1124 or C1126 detected?

- YES >> Proceed to diagnosis procedure. Refer to [BRC-69, "Diagnosis Procedure"](#).
NO >> Inspection End.

Diagnosis Procedure

INFOID:000000007641999

Regarding Wiring Diagram information, refer to [BRC-44, "Wiring Diagram"](#).

1. CONNECTOR INSPECTION

1. Turn ignition switch OFF.
2. Disconnect ABS actuator and electric unit (control unit) connector.
3. Check connector and terminals for deformation, disconnection, looseness or damage.

Is the inspection result normal?

- YES >> GO TO 2
NO >> Repair or replace as necessary.

2. CHECK ABS ACTUATOR AND ELECTRIC UNIT (CONTROL UNIT) BATTERY POWER SUPPLY

Check voltage between ABS actuator and electric unit (control unit) connector E33 terminal 25 and ground.

| ABS actuator and electric unit (control unit) | | — | Voltage (Approx.) |
|---|----------|--------|-------------------|
| Connector | Terminal | | |
| E33 | 25 | Ground | Battery voltage |

Is the inspection result normal?

- YES >> GO TO 3.
NO >> Repair or replace malfunctioning components.

3. CHECK ABS ACTUATOR AND ELECTRIC UNIT (CONTROL UNIT) GROUND CIRCUIT

Check continuity between ABS actuator and electric unit (control unit) connector E33 terminals 13, 38 and ground.

C1120, C1122, C1124, C1126 ABS IN VALVE SYSTEM

< DTC/CIRCUIT DIAGNOSIS >

[VDC/TCS/ABS]

| ABS actuator and electric unit (control unit) | | — | Continuity |
|---|----------|--------|------------|
| Connector | Terminal | | |
| E33 | 13 | Ground | Yes |
| | 38 | | |

Is the inspection result normal?

YES >> Replace ABS actuator and electric unit (control unit). Refer to [BRC-107, "Removal and Installation"](#).

NO >> Repair or replace malfunctioning components.

C1121, C1123, C1125, C1127 ABS OUT VALVE SYSTEM

< DTC/CIRCUIT DIAGNOSIS >

[VDC/TCS/ABS]

C1121, C1123, C1125, C1127 ABS OUT VALVE SYSTEM

DTC Logic

INFOID:000000007642000

DTC DETECTION LOGIC

| DTC | Display Item | Malfunction detected condition | Possible causes |
|-------|-------------------|---|---|
| C1121 | FR LH OUT ABS SOL | When a malfunction is detected in front LH ABS OUT valve. | <ul style="list-style-type: none">• Harness or connector• ABS actuator and electric unit (control unit)• Fusible link• Battery power supply system |
| C1123 | FR RH OUT ABS SOL | When a malfunction is detected in front RH ABS OUT valve. | |
| C1125 | RR LH OUT ABS SOL | When a malfunction is detected in rear LH ABS OUT valve. | |
| C1127 | RR RH OUT ABS SOL | When a malfunction is detected in rear RH ABS OUT valve. | |

DTC CONFIRMATION PROCEDURE

1. CHECK SELF DIAGNOSTIC RESULT

☑ With CONSULT.

1. Turn ignition switch ON.
2. Perform self diagnostic result.

Is DTC C1121, C1123, C1125 or C1127 detected?

- YES >> Proceed to diagnosis procedure. Refer to [BRC-71, "Diagnosis Procedure"](#).
NO >> Inspection End.

Diagnosis Procedure

INFOID:000000007642001

Regarding Wiring Diagram information, refer to [BRC-44, "Wiring Diagram"](#).

1. CONNECTOR INSPECTION

1. Turn ignition switch OFF.
2. Disconnect ABS actuator and electric unit (control unit) connector.
3. Check connector and terminals for deformation, disconnection, looseness or damage.

Is the inspection result normal?

- YES >> GO TO 2
NO >> Repair or replace as necessary.

2. CHECK ABS ACTUATOR AND ELECTRIC UNIT (CONTROL UNIT) BATTERY POWER SUPPLY

Check voltage between ABS actuator and electric unit (control unit) connector E33 terminal 25 and ground.

| ABS actuator and electric unit (control unit) | | — | Voltage (Approx.) |
|---|----------|--------|-------------------|
| Connector | Terminal | | |
| E33 | 25 | Ground | Battery voltage |

Is the inspection result normal?

- YES >> GO TO 3.
NO >> Repair or replace malfunctioning components.

3. CHECK ABS ACTUATOR AND ELECTRIC UNIT (CONTROL UNIT) GROUND CIRCUIT

Check continuity between ABS actuator and electric unit (control unit) connector E33 terminals 13, 38 and ground.

C1121, C1123, C1125, C1127 ABS OUT VALVE SYSTEM

< DTC/CIRCUIT DIAGNOSIS >

[VDC/TCS/ABS]

| ABS actuator and electric unit (control unit) | | — | Continuity |
|---|----------|--------|------------|
| Connector | Terminal | | |
| E33 | 13 | Ground | Yes |
| | 38 | | |

Is the inspection result normal?

YES >> Replace ABS actuator and electric unit (control unit). Refer to [BRC-107, "Removal and Installation"](#).

NO >> Repair or replace malfunctioning components.

C1130 ENGINE SIGNAL

< DTC/CIRCUIT DIAGNOSIS >

[VDC/TCS/ABS]

C1130 ENGINE SIGNAL

DTC Logic

INFOID:000000007642002

DTC DETECTION LOGIC

| DTC | Display Item | Malfunction detected condition | Possible causes |
|-------|-----------------|---|--|
| C1130 | ENGINE SIGNAL 1 | When a malfunction is detected in ECM system. | <ul style="list-style-type: none">• ECM• ABS actuator and electric unit (control unit)• CAN communication line |

DTC CONFIRMATION PROCEDURE

1. CHECK SELF DIAGNOSTIC RESULT

Ⓜ With CONSULT.

1. Turn ignition switch ON.
2. Perform self diagnostic result.

Is DTC C1130 detected?

- YES >> Proceed to diagnosis procedure. Refer to [BRC-73, "Diagnosis Procedure"](#).
NO >> Inspection End.

Diagnosis Procedure

INFOID:000000007642003

1. CHECK SELF DIAGNOSTIC RESULT FOR ENGINE SYSTEM

Ⓜ With CONSULT.

Perform self diagnostic result. Refer to [EC-59, "CONSULT Function"](#).

Are any ECM DTCs detected?

- YES >> Refer to [EC-82, "DTC Index"](#).
NO >> GO TO 2.

2. CHECK SELF DIAGNOSTIC RESULT FOR ABS ACTUATOR AND ELECTRIC UNIT (CONTROL UNIT)

Ⓜ With CONSULT.

1. Perform self diagnostic result and erase DTCs.
2. Turn ignition switch OFF.
3. Start engine and drive vehicle for a short period of time.
4. Check that malfunction indicator lamp (MIL) turns OFF.
5. Stop vehicle and perform self diagnostic result.

Is DTC C1130 detected?

- YES >> Replace ABS actuator and electric unit (control unit). Refer to [BRC-107, "Removal and Installation"](#).
NO >> Check pin terminals and connection of connectors for abnormal conditions. Repair or replace malfunctioning components.

C1140 ACTUATOR RELAY SYSTEM

< DTC/CIRCUIT DIAGNOSIS >

[VDC/TCS/ABS]

C1140 ACTUATOR RELAY SYSTEM

DTC Logic

INFOID:000000007642004

DTC DETECTION LOGIC

| DTC | Display Item | Malfunction detected condition | Possible causes |
|-------|--------------|---|---|
| C1140 | ACTUATOR RLY | When a malfunction is detected in actuator relay. | <ul style="list-style-type: none">• Harness or connector• ABS actuator and electric unit (control unit)• Fusible link• Battery power supply system |

DTC CONFIRMATION PROCEDURE

1. CHECK SELF DIAGNOSTIC RESULT

Ⓜ With CONSULT.

1. Turn ignition switch ON.
2. Perform self diagnostic result.

Is DTC C1140 detected?

- YES >> Proceed to diagnosis procedure. Refer to [BRC-74, "Diagnosis Procedure"](#).
NO >> Inspection End.

Diagnosis Procedure

INFOID:000000007642005

Regarding Wiring Diagram information, refer to [BRC-44, "Wiring Diagram"](#).

1. CONNECTOR INSPECTION

1. Turn ignition switch OFF.
2. Disconnect ABS actuator and electric unit (control unit) connector.
3. Check connector and terminals for deformation, disconnection, looseness or damage.

Is the inspection result normal?

- YES >> GO TO 2
NO >> Repair or replace as necessary.

2. CHECK ABS ACTUATOR AND ELECTRIC UNIT (CONTROL UNIT) BATTERY POWER SUPPLY

Check voltage between ABS actuator and electric unit (control unit) connector E33 terminal 25 and ground.

| ABS actuator and electric unit (control unit) | | — | Voltage (Approx.) |
|---|----------|--------|-------------------|
| Connector | Terminal | | |
| E33 | 25 | Ground | Battery voltage |

Is the inspection result normal?

- YES >> GO TO 3.
NO >> Repair or replace malfunctioning components.

3. CHECK ABS ACTUATOR AND ELECTRIC UNIT (CONTROL UNIT) GROUND CIRCUIT

Check continuity between ABS actuator and electric unit (control unit) connector E33 terminals 13, 38 and ground.

| ABS actuator and electric unit (control unit) | | — | Continuity |
|---|----------|--------|------------|
| Connector | Terminal | | |
| E33 | 13 | Ground | Yes |
| | 38 | | |

C1140 ACTUATOR RELAY SYSTEM

[VDC/TCS/ABS]

< DTC/CIRCUIT DIAGNOSIS >

Is the inspection result normal?

- YES >> Replace ABS actuator and electric unit (control unit). Refer to [BRC-107, "Removal and Installation"](#).
- NO >> Repair or replace malfunctioning components.

A
B
C
D
E
G
H
I
J
K
L
M
N
O
P

BRC

C1142 PRESS SENSOR

[VDC/TCS/ABS]

< DTC/CIRCUIT DIAGNOSIS >

C1142 PRESS SENSOR

DTC Logic

INFOID:000000007642006

DTC DETECTION LOGIC

| DTC | Display Item | Malfunction detected condition | Possible causes |
|-------|-------------------|--|--|
| C1142 | PRESS SEN CIRCUIT | When a malfunction is detected in master cylinder pressure sensor. | <ul style="list-style-type: none">• Stop lamp switch system• ABS actuator and electric unit (control unit)• Brake system |

DTC CONFIRMATION PROCEDURE

1. CHECK SELF DIAGNOSTIC RESULT

Ⓜ With CONSULT.

1. Turn ignition switch ON.
2. Perform self diagnostic result.

Is DTC C1142 detected?

- YES >> Proceed to diagnosis procedure. Refer to [BRC-76, "Diagnosis Procedure"](#).
NO >> Inspection End.

Diagnosis Procedure

INFOID:000000007642007

1. CHECK STOP LAMP SWITCH SYSTEM

Check stop lamp switch system. Refer to [BRC-67, "Diagnosis Procedure"](#).

Is the inspection result normal?

- YES >> GO TO 2.
NO >> Repair or replace malfunctioning components.

2. CHECK BRAKE FLUID LEAKAGE

Check brake fluid leakage. Refer to [BR-11, "Inspection"](#).

Is the inspection result normal?

- YES >> GO TO 3.
NO >> Repair or replace malfunctioning components.

3. CHECK BRAKE PEDAL

Check brake pedal. Refer to [BR-8, "Inspection and Adjustment"](#).

Is the inspection result normal?

- YES >> GO TO 4.
NO >> Repair or replace malfunctioning components.

4. CHECK SELF DIAGNOSTIC RESULT

Ⓜ With CONSULT.

1. Turn ignition switch ON.
2. Perform self diagnostic result.
3. Erase DTCs.
4. Start engine and drive vehicle for a short period of time.
5. Turn ignition switch ON.
6. Perform self diagnostic result.

Is DTC C1142 detected?

- YES >> Replace ABS actuator and electric unit (control unit). Refer to [BRC-107, "Removal and Installation"](#).
NO >> Inspection End.

C1143 STEERING ANGLE SENSOR

< DTC/CIRCUIT DIAGNOSIS >

[VDC/TCS/ABS]

C1143 STEERING ANGLE SENSOR

DTC Logic

INFOID:000000007642008

DTC DETECTION LOGIC

| DTC | Display Item | Malfunction detected condition | Possible causes |
|-------|--------------------|--|--|
| C1143 | ST ANG SEN CIRCUIT | When a malfunction is detected in steering angle sensor. | <ul style="list-style-type: none"> • Harness or connector • Steering angle sensor • ABS actuator and electric unit (control unit) • Fuse • Ignition power supply system • CAN communication line |

DTC CONFIRMATION PROCEDURE

1.CHECK SELF DIAGNOSTIC RESULT

ⓂWith CONSULT.

1. Turn ignition switch ON.
2. Perform self diagnostic result.

Is DTC C1143 detected?

- YES >> Proceed to diagnosis procedure. Refer to [BRC-77, "Diagnosis Procedure"](#).
 NO >> Inspection End.

Diagnosis Procedure

INFOID:000000007642009

Regarding Wiring Diagram information, refer to [BRC-44, "Wiring Diagram"](#).

1.CONNECTOR INSPECTION

1. Turn ignition switch OFF.
2. Disconnect ABS actuator and electric unit (control unit) and steering angle sensor connectors.
3. Check connectors and terminals for deformation, disconnection, looseness or damage.

Is the inspection result normal?

- YES >> GO TO 2
 NO >> Repair or replace as necessary.

2.CHECK STEERING ANGLE SENSOR MOUNTING CONDITION

Check steering angle sensor mounting condition.

Is the inspection result normal?

- YES >> GO TO 3.
 NO >> Repair or replace malfunctioning components.

3.CHECK STEERING ANGLE SENSOR POWER SUPPLY

1. Turn ignition switch OFF.
2. Disconnect steering angle sensor connector.
3. Turn ignition switch ON.
4. Check voltage between steering angle sensor connector M64 terminal 4 and ground.

| Steering angle sensor | | — | Voltage (Approx.) |
|-----------------------|----------|--------|-------------------|
| Connector | Terminal | | |
| M64 | 4 | Ground | Battery voltage |

Is the inspection result normal?

- YES >> GO TO 5.

C1143 STEERING ANGLE SENSOR

[VDC/TCS/ABS]

< DTC/CIRCUIT DIAGNOSIS >

NO >> GO TO 4.

4. CHECK STEERING ANGLE SENSOR POWER SUPPLY CIRCUIT

1. Turn ignition switch OFF.
2. Disconnect IPDM E/R connector E45.
3. Check continuity between steering angle sensor connector M64 terminal 4 and IPDM E/R connector E45 terminal 20.

| Steering angle sensor | | IPDM E/R | | Continuity |
|-----------------------|----------|-----------|----------|------------|
| Connector | Terminal | Connector | Terminal | |
| M64 | 4 | E45 | 20 | Yes |

4. Check continuity between steering angle sensor connector M64 terminal 4 and ground.

| Steering angle sensor | | — | Continuity |
|-----------------------|----------|--------|------------|
| Connector | Terminal | | |
| M64 | 4 | Ground | No |

Is the inspection result normal?

YES >> Perform trouble diagnosis for ignition power supply. Refer to [PG-20, "Wiring Diagram — Ignition Power Supply —"](#).

NO >> Repair or replace malfunctioning components.

5. CHECK STEERING ANGLE SENSOR GROUND CIRCUIT

1. Turn ignition switch OFF.
2. Check continuity between steering angle sensor connector M64 terminal 1 and ground.

| Steering angle sensor | | — | Continuity |
|-----------------------|----------|--------|------------|
| Connector | Terminal | | |
| M64 | 1 | Ground | Yes |

Is the inspection result normal?

YES >> GO TO 6.

NO >> Repair or replace malfunctioning components.

6. CHECK CAN COMMUNICATION LINE

Check "STRG BRANCH LINE CIRCUIT". Refer to [LAN-58, "Diagnosis Procedure"](#) (type 1) or [LAN-71, "Diagnosis Procedure"](#) (type 2).

Is the inspection result normal?

YES >> Replace ABS actuator and electric unit (control unit). Refer to [BRC-107, "Removal and Installation"](#).

NO >> Repair or replace malfunctioning components.

C1144 INCOMPLETE STEERING ANGLE SENSOR ADJUSTMENT

< DTC/CIRCUIT DIAGNOSIS >

[VDC/TCS/ABS]

C1144 INCOMPLETE STEERING ANGLE SENSOR ADJUSTMENT

DTC Logic

INFOID:000000007642010

DTC DETECTION LOGIC

| DTC | Display Item | Malfunction detected condition | Possible causes |
|-------|-------------------|--|--|
| C1144 | ST ANG SEN SIGNAL | When neutral position adjustment of steering angle sensor is not complete. | <ul style="list-style-type: none">• Harness or connector• Steering angle sensor• ABS actuator and electric unit (control unit)• Incomplete neutral position adjustment of steering angle sensor |

DTC CONFIRMATION PROCEDURE

1. CHECK SELF DIAGNOSTIC RESULT

Ⓜ With CONSULT.

1. Turn ignition switch ON.
2. Perform self diagnostic result.

Is DTC C1144 detected?

- YES >> Proceed to diagnosis procedure. Refer to [BRC-79, "Diagnosis Procedure"](#).
NO >> Inspection End.

Diagnosis Procedure

INFOID:000000007642011

1. ADJUST THE NEUTRAL POSITION OF STEERING ANGLE SENSOR

Perform neutral position adjustment of steering angle sensor. Refer to [BRC-54, "Work Procedure"](#).

>> GO TO 2.

2. CHECK SELF DIAGNOSTIC RESULT

Ⓜ With CONSULT.

Perform self diagnostic result.

Is DTC C1144 detected?

- YES >> GO TO 3.
NO >> Inspection End.

3. CHECK STEERING ANGLE SENSOR SYSTEM

Check steering angle sensor system. Refer to [BRC-77, "Diagnosis Procedure"](#).

Is the inspection result normal?

- YES >> Replace ABS actuator and electric unit (control unit). Refer to [BRC-107, "Removal and Installation"](#).
NO >> Repair or replace malfunctioning components.

C1145, C1146 YAW RATE/SIDE/DECEL G SENSOR

< DTC/CIRCUIT DIAGNOSIS >

[VDC/TCS/ABS]

C1145, C1146 YAW RATE/SIDE/DECEL G SENSOR

DTC Logic

INFOID:000000007642012

DTC DETECTION LOGIC

| DTC | Display Item | Malfunction detected condition | Possible causes |
|-------|--------------------|--|---|
| C1145 | YAW RATE SENSOR | <ul style="list-style-type: none">• When a malfunction is detected in yaw rate signal.• When yaw rate signal is not continuously received for 2 seconds or more.• When side G signal is not continuously received for 2 seconds or more.• When decel G signal is not continuously received for 2 seconds or more. | <ul style="list-style-type: none">• Harness or connector• Yaw rate/side/decel G sensor• ABS actuator and electric unit (control unit)• Ignition power supply system• Fuse |
| C1146 | SIDE G-SEN CIRCUIT | When a malfunction is detected in side/decel G signal. | |

DTC CONFIRMATION PROCEDURE

1. CHECK SELF DIAGNOSTIC RESULT

Ⓜ With CONSULT.

1. Turn ignition switch OFF to ON.
2. Perform self diagnostic result.

Is DTC C1145 or C1146 detected?

- YES >> Proceed to diagnosis procedure. Refer to [BRC-80, "Diagnosis Procedure"](#).
NO >> Inspection End.

Diagnosis Procedure

INFOID:000000007642013

1. REPLACE ABS ACTUATOR AND ELECTRIC UNIT (CONTROL UNIT)

Replace ABS actuator and electric unit (control unit).

- >> Replace ABS actuator and electric unit (control unit). Refer to [BRC-107, "Removal and Installation"](#).

C1155 BR FLUID LEVEL LOW

< DTC/CIRCUIT DIAGNOSIS >

[VDC/TCS/ABS]

C1155 BR FLUID LEVEL LOW

DTC Logic

INFOID:000000007642050

DTC DETECTION LOGIC

| DTC | Display item | Malfunction detected condition | Possible cause |
|-------|--------------------|---|---|
| C1155 | BR FLUID LEVEL LOW | Brake fluid level is low or communication line between the ABS actuator and electric unit (control unit) and brake fluid level switch is open or shorted. | <ul style="list-style-type: none">• Harness or connector• Brake fluid level switch |

DTC CONFIRMATION PROCEDURE

1. CHECK SELF-DIAGNOSIS RESULTS

Check the self-diagnosis results.

| |
|------------------------|
| Self-diagnosis results |
| BR FLUID LEVEL LOW |

Is above displayed on the self-diagnosis display?

- YES >> Proceed to diagnosis procedure. Refer to [BRC-81, "Diagnosis Procedure"](#).
NO >> Inspection End.

Diagnosis Procedure

INFOID:000000007642051

Regarding Wiring Diagram information, refer to [BRC-44, "Wiring Diagram"](#).

NOTE:

Check brake fluid level in brake reservoir tank before starting inspection.

1. CONNECTOR INSPECTION

1. Turn ignition switch OFF.
2. Disconnect combination meter and brake fluid level switch connectors.
3. Check connectors and terminals for deformation, disconnection, looseness or damage.

Is the inspection result normal?

- YES >> GO TO 2
NO >> Repair or replace as necessary.

2. CHECK BRAKE FLUID LEVEL SWITCH

Perform the brake fluid level switch component inspection. Refer to [BRC-82, "Component Inspection"](#).

Is the inspection result normal?

- YES >> GO TO 3
NO >> Replace brake fluid level switch. Refer to [BR-27, "Exploded View"](#).

3. CHECK BRAKE FLUID LEVEL SWITCH HARNESS

1. Check continuity between combination meter connector and brake fluid level switch connector E40 terminal 1.

| Combination meter | | Brake fluid level switch | | Continuity |
|-------------------|----------|--------------------------|----------|------------|
| Connector | Terminal | Connector | Terminal | |
| M82 (with Type A) | 11 | E40 | 1 | Yes |
| M24 (with Type B) | 36 | | | |

2. Check continuity between combination meter connector and ground.

C1155 BR FLUID LEVEL LOW

< DTC/CIRCUIT DIAGNOSIS >

[VDC/TCS/ABS]

| Combination meter | | — | Continuity |
|-------------------|----------|--------|------------|
| Connector | Terminal | | |
| M82 (with Type A) | 11 | Ground | No |
| M24 (with Type B) | 36 | | |

Is the inspection result normal?

YES >> GO TO 4

NO >> Repair or replace malfunctioning components.

4. CHECK BRAKE FLUID LEVEL SWITCH GROUND CIRCUIT

Check continuity between brake fluid level switch connector E40 terminal 2 and ground.

| Brake fluid level switch | | — | Continuity |
|--------------------------|----------|--------|------------|
| Connector | Terminal | | |
| E40 | 2 | Ground | No |

Is the inspection result normal?

YES >> Replace ABS actuator and electric unit (control unit). Refer to [BRC-107. "Removal and Installation"](#)

NO >> Repair or replace malfunctioning components.

Component Inspection

INFOID:000000007642052

1. CHECK BRAKE FLUID LEVEL SWITCH

1. Turn ignition switch OFF.
2. Disconnect brake fluid level switch connector.
3. Check continuity between brake fluid level switch terminals 1 and 2.

| Brake fluid level switch terminals | Condition | Continuity |
|------------------------------------|-----------------------------|------------|
| 1—2 | Brake fluid reservoir full | No |
| | Brake fluid reservoir empty | Yes |

Is the inspection result normal?

YES >> Inspection End.

NO >> Replace brake fluid level switch. Refer to [BR-27. "Exploded View"](#).

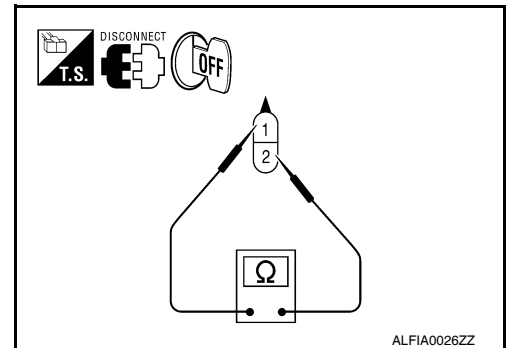

C1164, C1165, C1166, C1167 CV/SV SYSTEM

< DTC/CIRCUIT DIAGNOSIS >

[VDC/TCS/ABS]

C1164, C1165, C1166, C1167 CV/SV SYSTEM

DTC Logic

INFOID:000000007642017

DTC DETECTION LOGIC

| DTC | Display Item | Malfunction detected condition | Possible causes |
|-------|--------------|--|---|
| C1164 | CV 1 | When a malfunction is detected in cut valve 1. | <ul style="list-style-type: none">• Harness or connector• ABS actuator and electric unit (control unit)• Fusible link• Battery power supply system |
| C1165 | CV 2 | When a malfunction is detected in cut valve 2. | |
| C1166 | SV 1 | When a malfunction is detected in suction valve 1. | |
| C1167 | SV 2 | When a malfunction is detected in suction valve 2. | |

DTC CONFIRMATION PROCEDURE

1. CHECK SELF DIAGNOSTIC RESULT

 With CONSULT.

1. Turn ignition switch OFF to ON.
2. Perform self diagnostic result.

Is DTC C1164, C1165, C1166 or C1167 detected?

- YES >> Proceed to diagnosis procedure. Refer to [BRC-83. "Diagnosis Procedure"](#).
NO >> Inspection End.

Diagnosis Procedure

INFOID:000000007642018

Regarding Wiring Diagram information, refer to [BRC-44. "Wiring Diagram"](#).

1. CONNECTOR INSPECTION

1. Turn ignition switch OFF.
2. Disconnect ABS actuator and electric unit (control unit) connector.
3. Check connector and terminals for deformation, disconnection, looseness or damage.

Is the inspection result normal?

- YES >> GO TO 2
NO >> Repair or replace as necessary.

2. CHECK ABS ACTUATOR AND ELECTRIC UNIT (CONTROL UNIT) BATTERY POWER SUPPLY

Check voltage between ABS actuator and electric unit (control unit) connector E33 terminal 25 and ground.

| ABS actuator and electric unit (control unit) | | — | Voltage (Approx.) |
|---|----------|--------|-------------------|
| Connector | Terminal | | |
| E33 | 25 | Ground | Battery voltage |

Is the inspection result normal?

- YES >> GO TO 3.
NO >> Repair or replace malfunctioning components.

3. CHECK ABS ACTUATOR AND ELECTRIC UNIT (CONTROL UNIT) GROUND CIRCUIT

Check continuity between ABS actuator and electric unit (control unit) connector E33 terminals 13, 38 and ground.

| ABS actuator and electric unit (control unit) | | — | Continuity |
|---|----------|--------|------------|
| Connector | Terminal | | |
| E33 | 13 | Ground | Yes |
| | 38 | | |

A
B
C
D
E
BRC
G
H
I
J
K
L
M
N
O
P

C1164, C1165, C1166, C1167 CV/SV SYSTEM

< DTC/CIRCUIT DIAGNOSIS >

[VDC/TCS/ABS]

Is the inspection result normal?

- YES >> Replace ABS actuator and electric unit (control unit). Refer to [BRC-107, "Removal and Installation"](#).
- NO >> Repair or replace malfunctioning components.

U1000 CAN COMM CIRCUIT

< DTC/CIRCUIT DIAGNOSIS >

[VDC/TCS/ABS]

U1000 CAN COMM CIRCUIT

DTC Logic

INFOID:000000007642020

DTC DETECTION LOGIC

| DTC | Display Item | Malfunction detected condition | Possible causes |
|-------|------------------|--|--------------------------------------|
| U1000 | CAN COMM CIRCUIT | When CAN communication signal is not continuously received for 2 seconds or more | CAN communication system malfunction |

Diagnosis Procedure

INFOID:000000007642021

1. CHECK DTC DETECTION

Ⓜ With CONSULT.

1. Turn ignition switch ON.
2. Perform self diagnostic result.

Is DTC U1000 detected?

- YES >> Proceed to diagnosis procedure. Refer to [LAN-14. "Trouble Diagnosis Flow Chart"](#).
NO >> Refer to [GI-38. "Intermittent Incident"](#).

A
B
C
D
E
BRC
G
H
I
J
K
L
M
N
O
P

U1002 SYSTEM COMM (CAN)

DTC Logic

INFOID:000000007616522

DTC DETECTION LOGIC

| DTC | Display item | Malfunction detected condition | Possible cause |
|-------|------------------|---|---|
| U1002 | SYSTEM COMM(CAN) | When ABS actuator and electric unit (control unit) is not transmitting or receiving CAN communication signal for 2 seconds or less. | <ul style="list-style-type: none"> • CAN communication line • ABS actuator and electric unit (control unit) |

DTC CONFIRMATION PROCEDURE

1. PRECONDITIONING

If "DTC CONFIRMATION PROCEDURE" has been previously conducted, always turn ignition switch OFF and wait at least 10 seconds before conducting the next test.

>> GO TO 2.

2. DTC REPRODUCTION PROCEDURE

Ⓜ With CONSULT

1. Turn the ignition switch ON.
2. Perform self diagnosis for "ABS".

Is DTC "U1002" detected?

- YES >> Proceed to [BRC-86, "Diagnosis Procedure"](#).
 NO >> Inspection End.

Diagnosis Procedure

INFOID:000000007616523

CAUTION:

- Never apply 7.0 V or more to the measurement terminal.
- Use a tester with open terminal voltage of 7.0 V or less.
- Turn the ignition switch OFF and disconnect the battery cable from the negative terminal when checking the harness.

1. CHECK CAN DIAGNOSIS SUPPORT MONITOR

1. Select "ABS" and "CAN Diagnosis Support Monitor" in order with CONSULT.
2. Check malfunction history between each control unit connected to ABS actuator and electric unit (control unit).

Check the result of "PAST"?

All items are "OK">>Refer to [GI-38, "Intermittent Incident"](#).
 "TRANSMIT DIAG" is other than "OK">>GO TO 2.

A control unit other than ABS actuator and electric unit (control unit) is anything other than "OK">>GO TO 3.

2. CHECK TRANSMITTING SIDE UNIT

Check the ABS actuator and electric unit (control unit) harness connector terminals 14 and 26 for damage or loose connection.

Is the inspection result normal?

- YES >> Erase self-diagnosis results. Then perform self-diagnosis for "ABS" with CONSULT.
 NO >> Recheck terminals for damage or loose connection.

3. CHECK APPLICABLE CONTROL UNIT

Check damage or loose connection of each CAN communication line harness connector terminals.

Is the inspection result normal?

- YES >> Erase self-diagnosis results. Then perform self-diagnosis for applicable control unit with CONSULT.
 NO >> Recheck terminals for damage or loose connection.

PARKING BRAKE SWITCH

< DTC/CIRCUIT DIAGNOSIS >

[VDC/TCS/ABS]

PARKING BRAKE SWITCH

Component Function Check

INFOID:000000007642022

1. CHECK PARKING BRAKE SWITCH OPERATION

Check that brake warning lamp in combination meter turns ON/OFF when parking brake is actuated.

Is the inspection result normal?

YES >> Inspection End.

NO >> Proceed to diagnosis procedure. Refer to [BRC-87, "Diagnosis Procedure"](#).

Diagnosis Procedure

INFOID:000000007642023

Regarding Wiring Diagram information, refer to [BRC-44, "Wiring Diagram"](#).

1. CONNECTOR INSPECTION

1. Turn ignition switch OFF.
2. Disconnect combination meter and parking brake switch connectors.
3. Check connectors and terminals for deformation, disconnection, looseness or damage.

Is the inspection result normal?

YES >> GO TO 2

NO >> Repair or replace as necessary.

2. CHECK PARKING BRAKE SWITCH

Check parking brake switch. Refer to [BRC-88, "Component Inspection"](#).

Is the inspection result normal?

YES >> GO TO 3.

NO >> Replace parking brake switch. Refer to [PB-6, "Exploded View"](#).

3. CHECK PARKING BRAKE SWITCH SIGNAL

Ⓜ With CONSULT.

1. Connect combination meter connector and parking brake switch connectors.
2. Turn ignition switch ON.
3. In "DATA MONITOR" select "PARK BRAKE SW" and check parking brake switch signal.

| Condition | DATA MONITOR |
|-----------------------|--------------|
| Actuate parking brake | On |
| Release parking brake | Off |

Is the inspection result normal?

YES >> Refer to [BRC-51, "Work Flow"](#).

NO >> GO TO 4.

4. CHECK PARKING BRAKE SWITCH CIRCUIT

1. Turn ignition switch OFF.
2. Disconnect combination meter and parking brake switch connectors.
3. Check continuity between combination meter connector and parking brake switch connector M17 terminal 1.

| Combination meter | | Parking brake switch | | Continuity |
|-------------------|----------|----------------------|----------|------------|
| Connector | Terminal | Connector | Terminal | |
| M82 (type A) | 10 | M17 | 1 | Yes |
| M24 (type B) | 37 | | | |

4. Check continuity between combination meter connector and ground.

PARKING BRAKE SWITCH

< DTC/CIRCUIT DIAGNOSIS >

[VDC/TCS/ABS]

| Combination meter | | — | Continuity |
|-------------------|----------|--------|------------|
| Connector | Terminal | | |
| M82 (type A) | 10 | Ground | No |
| M24 (type B) | 37 | | |

Is the inspection result normal?

YES >> Replace combination meter. Refer to [MWI-52, "Removal and Installation"](#) (type A) or [MWI-101, "Removal and Installation"](#) (type B).

NO >> Repair or replace malfunctioning components.

Component Inspection

INFOID:000000007642024

1. CHECK PARKING BRAKE SWITCH

1. Turn ignition switch OFF.
2. Disconnect parking brake switch connector.
3. Check continuity between parking brake switch terminal 1 and ground.

| Parking brake switch terminal | — | Condition | Continuity |
|-------------------------------|--------|------------------------|------------|
| 1 | Ground | Parking brake actuated | Yes |
| | | Parking brake released | No |

Is the inspection result normal?

YES >> Inspection End.

NO >> Replace parking brake switch. Refer to [PB-6, "Exploded View"](#).

VDC OFF SWITCH

< DTC/CIRCUIT DIAGNOSIS >

[VDC/TCS/ABS]

VDC OFF SWITCH

Component Function Check

INFOID:000000007642025

1. CHECK VDC OFF SWITCH OPERATION

Check that VDC OFF indicator lamp in combination meter turns ON/OFF when VDC OFF switch is operated.

Is the inspection result normal?

YES >> Inspection End.

NO >> Proceed to diagnosis procedure. Refer to [BRC-89, "Diagnosis Procedure"](#).

Diagnosis Procedure

INFOID:000000007642026

Regarding Wiring Diagram information, refer to [BRC-44, "Wiring Diagram"](#).

1. CONNECTOR INSPECTION

1. Turn ignition switch OFF.
2. Disconnect ABS actuator and electric unit (control unit) and VDC OFF switch connectors.
3. Check connectors and terminals for deformation, disconnection, looseness or damage.

Is the inspection result normal?

YES >> GO TO 2

NO >> Repair or replace as necessary.

2. CHECK VDC OFF SWITCH

Check VDC OFF switch. Refer to [BRC-90, "Component Inspection"](#).

Is the inspection result normal?

YES >> GO TO 3.

NO >> Replace VDC OFF switch. Refer to [BRC-109, "Removal and Installation"](#).

3. CHECK VDC OFF SWITCH SIGNAL

Ⓜ With CONSULT.

1. Connect ABS actuator and electric unit (control unit) and VDC OFF switch connectors.
2. Turn ignition switch ON.
3. In "DATA MONITOR" select "OFF SW" and check VDC OFF switch signal.

| Condition | DATA MONITOR |
|--|--------------|
| VDC OFF switch is pressed and released | On |
| VDC OFF switch is pressed and released again | Off |

Is the inspection result normal?

YES >> Refer to [BRC-51, "Work Flow"](#).

NO >> GO TO 4.

4. CHECK VDC OFF SWITCH CIRCUIT

1. Turn ignition switch OFF.
2. Disconnect ABS actuator and electric unit (control unit) and VDC OFF switch connectors.
3. Check continuity between ABS actuator and electric unit (control unit) connector E33 terminal 15 and VDC OFF switch connector M34 terminal 1.

| ABS actuator and electric unit (control unit) | | VDC OFF switch | | Continuity |
|---|----------|----------------|----------|------------|
| Connector | Terminal | Connector | Terminal | |
| E33 | 15 | M34 | 1 | Yes |

4. Check continuity between ABS actuator and electric unit (control unit) connector terminal E33 terminal 15 and ground.

A
B
C
D
E
G
H
I
J
K
L
M
N
O
P

BRC

VDC OFF SWITCH

< DTC/CIRCUIT DIAGNOSIS >

[VDC/TCS/ABS]

| ABS actuator and electric unit (control unit) | | — | Continuity |
|---|----------|--------|------------|
| Connector | Terminal | | |
| E33 | 15 | Ground | No |

Is the inspection result normal?

YES >> GO TO 5.

NO >> Repair or replace malfunctioning components.

5.CHECK VDC OFF SWITCH GROUND CIRCUIT

Check continuity between VDC OFF switch connector M34 terminal 2 and ground.

| VDC OFF switch | | — | Continuity |
|----------------|----------|--------|------------|
| Connector | Terminal | | |
| M34 | 2 | Ground | Yes |

Is the inspection result normal?

YES >> Replace ABS actuator and electric unit (control unit). Refer to [BRC-107, "Removal and Installation"](#).

NO >> Repair or replace malfunctioning components.

Component Inspection

INFOID:000000007642027

1.CHECK VDC OFF SWITCH

1. Turn ignition switch OFF.
2. Disconnect VDC OFF switch connector.
3. Check continuity between terminals of VDC OFF switch connector.

| VDC OFF switch terminals | Condition | Continuity |
|--------------------------|-------------------------|------------|
| 1 – 2 | VDC OFF switch pressed | Yes |
| | VDC OFF switch released | No |

Is the inspection result normal?

YES >> Inspection End.

NO >> Replace VDC OFF switch. Refer to [BRC-109, "Removal and Installation"](#).

ABS WARNING LAMP

< DTC/CIRCUIT DIAGNOSIS >

[VDC/TCS/ABS]

ABS WARNING LAMP

Component Function Check

INFOID:000000007642028

1. CHECK ABS WARNING LAMP FUNCTION

Check that ABS warning lamp in combination meter turns ON for approximately 2 seconds after ignition switch is turned ON.

Is the inspection result normal?

YES >> Inspection End.

NO >> Proceed to diagnosis procedure. Refer to [BRC-91, "Diagnosis Procedure"](#).

Diagnosis Procedure

INFOID:000000007642029

1. PERFORM THE SELF-DIAGNOSIS

 With CONSULT.

Perform self diagnostic result.

Are any DTCs detected?

YES >> Refer to [BRC-42, "DTC Index"](#).

NO >> GO TO 2.

2. CHECK COMBINATION METER

Check if indication and operation of combination meter are normal. Refer to [MWI-9, "METER SYSTEM : System Description"](#) (type A) and [MWI-59, "METER SYSTEM : System Description"](#) (type B).

Is the inspection result normal?

YES >> Replace ABS actuator and electric unit (control unit). Refer to [BRC-107, "Removal and Installation"](#).

NO >> Replace combination meter. Refer to [MWI-52, "Removal and Installation"](#) (type A) or [MWI-101, "Removal and Installation"](#) (type B).

A
B
C
D
E
G
H
I
J
K
L
M
N
O
P

BRC

BRAKE WARNING LAMP

Component Function Check

INFOID:000000007642030

1. CHECK BRAKE WARNING LAMP FUNCTION (1)

Check that brake warning lamp in combination meter turns ON for approximately 2 seconds after ignition switch is turned ON.

Is the inspection result normal?

YES >> GO TO 2.

NO >> Proceed to diagnosis procedure. Refer to [BRC-92, "Diagnosis Procedure"](#).

2. CHECK BRAKE WARNING LAMP FUNCTION (2)

Check that brake warning lamp in combination meter turns ON/OFF when parking brake is operated.

Is the inspection result normal?

YES >> GO TO 3.

NO >> Check parking brake switch system. Refer to [BRC-87, "Diagnosis Procedure"](#).

Diagnosis Procedure

INFOID:000000007642031

1. PERFORM THE SELF-DIAGNOSIS

Ⓟ With CONSULT.

Perform self diagnostic result.

Are any DTCs detected?

YES >> Refer to [BRC-42, "DTC Index"](#).

NO >> GO TO 2.

2. CHECK COMBINATION METER

Check if indication and operation of combination meter are normal. Refer to [MWI-9, "METER SYSTEM : System Description"](#) (type A) and [MWI-59, "METER SYSTEM : System Description"](#) (type B).

Is the inspection result normal?

YES >> Replace ABS actuator and electric unit (control unit). Refer to [BRC-107, "Removal and Installation"](#).

NO >> Replace combination meter. Refer to [MWI-52, "Removal and Installation"](#) (type A) or [MWI-101, "Removal and Installation"](#) (type B).

VDC OFF INDICATOR LAMP

< DTC/CIRCUIT DIAGNOSIS >

[VDC/TCS/ABS]

VDC OFF INDICATOR LAMP

Component Function Check

INFOID:000000007642032

1. CHECK VDC OFF INDICATOR LAMP FUNCTION

Check that VDC OFF indicator lamp in combination meter turns ON for approximately 2 seconds after ignition switch is turned ON.

Is the inspection result normal?

YES >> Inspection End.

NO >> Proceed to diagnosis procedure. Refer to [BRC-93, "Diagnosis Procedure"](#).

Diagnosis Procedure

INFOID:000000007642033

1. PERFORM THE SELF-DIAGNOSIS

 With CONSULT.

Perform self diagnostic result.

Are any DTCs detected?

YES >> Refer to [BRC-42, "DTC Index"](#).

NO >> GO TO 2.

2. CHECK COMBINATION METER

Check if indication and operation of combination meter are normal. Refer to [MWI-9, "METER SYSTEM : System Description"](#) (type A) and [MWI-59, "METER SYSTEM : System Description"](#) (type B).

Is the inspection result normal?

YES >> Replace ABS actuator and electric unit (control unit). Refer to [BRC-107, "Removal and Installation"](#).

NO >> Replace combination meter. Refer to [MWI-52, "Removal and Installation"](#) (type A) or [MWI-101, "Removal and Installation"](#) (type B).

A
B
C
D
E
G
H
I
J
K
L
M
N
O
P

BRC

SLIP INDICATOR LAMP**Component Function Check**

INFOID:000000007642034

1.CHECK SLIP INDICATOR LAMP FUNCTION

Check that slip indicator lamp in combination meter turns ON for approximately 2 seconds after ignition switch is turned ON.

Is the inspection result normal?

YES >> Inspection End.

NO >> Proceed to diagnosis procedure. Refer to [BRC-94, "Diagnosis Procedure"](#).

Diagnosis Procedure

INFOID:000000007642035

1.PERFORM THE SELF-DIAGNOSIS

 With CONSULT.

Perform self diagnostic result.

Are any DTCs detected?

YES >> Refer to [BRC-42, "DTC Index"](#).

NO >> GO TO 2.

2.CHECK COMBINATION METER

Check if indication and operation of combination meter are normal. Refer to [MWI-9, "METER SYSTEM : System Description"](#) (type A) and [MWI-59, "METER SYSTEM : System Description"](#) (type B).

Is the inspection result normal?

YES >> Replace ABS actuator and electric unit (control unit). Refer to [BRC-107, "Removal and Installation"](#).

NO >> Replace combination meter. Refer to [MWI-52, "Removal and Installation"](#) (type A) or [MWI-101, "Removal and Installation"](#) (type B).

SYMPTOM DIAGNOSIS

VDC/TCS/ABS

Symptom Table

INFOID:000000007642036

If ABS warning lamp, VDC OFF indicator lamp and SLIP indicator lamp turn ON, perform self-diagnosis.

| Symptom | Check item | Reference |
|--|--|--|
| Excessive ABS function operation frequency | Brake force distribution | BRC-96. "Diagnosis Procedure" |
| | Looseness of front and rear axle | |
| | Wheel sensor and rotor system | |
| Unexpected pedal reaction | Brake pedal stroke | BRC-97. "Diagnosis Procedure" |
| | Make sure the braking force is sufficient when the ABS is not operating. | |
| The braking distance is long | Check stopping distance when the ABS is not operating. | BRC-98. "Diagnosis Procedure" |
| ABS function does not operate (Note 1) | ABS actuator and electric unit (control unit) | BRC-99. "Diagnosis Procedure" |
| Pedal vibration or ABS operation sound occurs (Note 2) | Brake pedal | BRC-100. "Diagnosis Procedure" |
| | ABS actuator and electric unit (control unit) | |
| Vehicle jerks during VDC/TCS/ABS control | ABS actuator and electric unit (control unit) | BRC-101. "Diagnosis Procedure" |
| | TCM | |
| | ECM | |

NOTE:

- 1: The ABS does not operate when the speed is 10 km/h (6 MPH) or less.
- 2: Under the following conditions, ABS is activated and vibration is felt when brake pedal is lightly depressed (just place a foot on it). However, this is normal.
 - When shifting gears
 - When driving on slippery road
 - During cornering at high speed
 - When passing over bumps or grooves [approximately 50 mm (1.97 in) or more]
 - When pulling away just after starting engine [at approximately 10 km/h (6 MPH) or higher]

EXCESSIVE ABS FUNCTION OPERATION FREQUENCY

< SYMPTOM DIAGNOSIS >

[VDC/TCS/ABS]

EXCESSIVE ABS FUNCTION OPERATION FREQUENCY

Diagnosis Procedure

INFOID:000000007642037

1. CHECK START

Check front and rear brake force distribution using a brake tester.

Is the inspection result normal?

- YES >> GO TO 2
- NO >> Check brake system.

2. CHECK FRONT AND REAR AXLE

Make sure that there is no excessive play in the front and rear axles. Refer to front: [FAX-7. "Inspection"](#), rear: [RAX-5. "Inspection"](#).

Is the inspection result normal?

- YES >> GO TO 3
- NO >> Repair or replace malfunctioning components.

3. CHECK WHEEL SENSOR AND SENSOR ROTOR

Check the following:

- Wheel sensor installation for damage
- Sensor rotor installation for damage
- Wheel sensor connector
- Wheel sensor harness

Is the inspection result normal?

- YES >> GO TO 4
- NO >>
 - Replace wheel sensor [BRC-103. "FRONT WHEEL SENSOR : Removal and Installation"](#) (front) or [BRC-106. "REAR SENSOR ROTOR : Removal and Installation"](#) (rear).
 - Replace sensor rotor [BRC-106. "FRONT SENSOR ROTOR : Removal and Installation"](#) (front) or [BRC-106. "REAR SENSOR ROTOR : Removal and Installation"](#) (rear).
 - Repair harness.

4. CHECK ABS WARNING LAMP DISPLAY

Make sure that the ABS warning lamp is turned off after the ignition switch is turned ON or when driving.

Is the inspection result normal?

- YES >> Inspection End.
- NO >> Perform self diagnostic result. Refer to [BRC-32. "CONSULT Function \(ABS\)"](#).

UNEXPECTED PEDAL REACTION

< SYMPTOM DIAGNOSIS >

[VDC/TCS/ABS]

UNEXPECTED PEDAL REACTION

Diagnosis Procedure

INFOID:000000007642038

1.CHECK BRAKE PEDAL STROKE

Check brake pedal stroke. Refer to [BR-8, "Inspection and Adjustment"](#).

Is the stroke too big?

- YES >> • Bleed air from brake line and hose. Refer to [BR-12, "Bleeding Brake System"](#).
• Check brake pedal, brake booster, and master cylinder for mount play, looseness, brake system fluid leakage, etc. Refer to brake pedal: [BR-8, "Inspection and Adjustment"](#) or brake booster assembly [BR-14, "Inspection"](#).

NO >> GO TO 2

2.CHECK ABS FUNCTION

1. Disconnect ABS actuator and electric unit (control unit) connector to deactivate ABS.
2. Check if braking force is normal in this condition.
3. Reconnect connector after inspection.

Is the inspection result normal?

- YES >> Inspection End.
NO >> Check brake system.

A
B
C
D
E
F
G
H
I
J
K
L
M
N
O
P

BRC

THE BRAKING DISTANCE IS LONG

< SYMPTOM DIAGNOSIS >

[VDC/TCS/ABS]

THE BRAKING DISTANCE IS LONG

Diagnosis Procedure

INFOID:000000007642039

CAUTION:

The stopping distance on slippery road surfaces might be longer with the ABS operating than when the ABS is not operating.

1. CHECK ABS FUNCTION

1. Turn ignition switch OFF.
2. Disconnect ABS actuator and electric unit (control unit) connector to deactivate ABS.
3. Check stopping distance.
4. After inspection, reconnect connector.

Is the inspection result normal?

- YES >> Inspection End.
NO >> Check brake system.

ABS FUNCTION DOES NOT OPERATE

< SYMPTOM DIAGNOSIS >

[VDC/TCS/ABS]

ABS FUNCTION DOES NOT OPERATE

Diagnosis Procedure

INFOID:000000007642040

CAUTION:

ABS does not operate when speed is 10 km/h (6 MPH) or lower.

1.CHECK ABS WARNING LAMP DISPLAY

Make sure that the ABS warning lamp turns OFF after ignition switch is turned ON or when driving.

Is the inspection result normal?

YES >> Inspection End.

NO >> Perform self diagnostic result. Refer to [BRC-32. "CONSULT Function \(ABS\)".](#)

A
B
C
D
E
G
H
I
J
K
L
M
N
O
P

BRC

PEDAL VIBRATION OR ABS OPERATION SOUND OCCURS

< SYMPTOM DIAGNOSIS >

[VDC/TCS/ABS]

PEDAL VIBRATION OR ABS OPERATION SOUND OCCURS

Diagnosis Procedure

INFOID:000000007642041

CAUTION:

Under the following conditions, ABS is activated and vibration is felt when brake pedal is lightly depressed (just place a foot on it). However, this is normal.

- When shifting gears
- When driving on slippery road
- During cornering at high speed
- When passing over bumps or grooves [approximately 50 mm (1.97 in) or more]
- When pulling away just after starting engine [at approximately 10 km/h (6 MPH) or higher]

1. SYMPTOM CHECK 1

Check that there are pedal vibrations when the engine is started.

Do symptoms occur?

- YES >> GO TO 2
NO >> Inspect the brake pedal.

2. SYMPTOM CHECK 2

Check that there are ABS operation noises when the engine is started.

Do symptoms occur?

- YES >> GO TO 3
NO >> Perform self diagnostic result. Refer to [BRC-32. "CONSULT Function \(ABS\)".](#)

3. SYMPTOM CHECK 3

Check symptoms when electrical component (headlamps, etc.) switches are operated.

Do symptoms occur?

- YES >> Check if there is a radio, antenna, antenna lead wire, or wiring close to the control unit. If there is, move it farther away.
NO >> Inspection End.

VEHICLE JERKS DURING VDC/TCS/ABS CONTROL

< SYMPTOM DIAGNOSIS >

[VDC/TCS/ABS]

VEHICLE JERKS DURING VDC/TCS/ABS CONTROL

Diagnosis Procedure

INFOID:000000007642042

1.SYMPTOM CHECK

Check if the vehicle jerks during VDC/TCS/ABS control.

Is the inspection result normal?

- YES >> Inspection End.
- NO >> GO TO 2

2.CHECK SELF DIAGNOSTIC RESULT

Perform self diagnostic result of ABS actuator and electric unit (control unit). Refer to [BRC-32. "CONSULT Function \(ABS\)"](#).

Are self diagnostic results indicated?

- YES >> Check corresponding items, make repairs, and perform ABS actuator and electric unit (control unit) self diagnostic result again. Refer to [BRC-32. "CONSULT Function \(ABS\)"](#).
- NO >> GO TO 3

3.CHECK CONNECTOR

1. Turn ignition switch OFF.
2. Disconnect ABS actuator and electric unit (control unit) connector.
3. Check terminals for deformation, disconnection, looseness, etc.
4. Securely reconnect connector and perform ABS actuator and electric unit (control unit) self diagnostic result. Refer to [BRC-32. "CONSULT Function \(ABS\)"](#).

Are self diagnostic results indicated?

- YES >> If poor contact, damage, open or short circuit of connector terminal is found, repair or replace.
- NO >> GO TO 4

4.CHECK ECM AND TCM SELF DIAGNOSTIC RESULT

1. Perform ECM self diagnostic result. Refer to [EC-59. "CONSULT Function"](#).
2. Perform TCM self diagnostic result. Refer to [TM-92. "CONSULT Function \(TRANSMISSION\)"](#).

Are self diagnostic results indicated?

- YES >> Check the corresponding items.
 - ECM: Refer to [EC-82. "DTC Index"](#).
 - TCM: Refer to [TM-111. "DTC Index"](#).
- NO >> Replace ABS actuator and electric unit (control unit). Refer to [BRC-107. "Removal and Installation"](#).

A
B
C
D
E
G
H
I
J
K
L
M
N
O
P

BRC

NORMAL OPERATING CONDITION

< SYMPTOM DIAGNOSIS >

[VDC/TCS/ABS]

NORMAL OPERATING CONDITION

Description

INFOID:000000007642043

| Symptom | Result |
|--|---|
| Slight vibrations are felt on the brake pedal and operation noises occur when VDC, TCS or ABS is activated. | This is a normal condition due to the VDC, TCS or ABS activation. |
| Stopping distance is longer than that of vehicles without ABS when the vehicle drives on rough, gravel, or snow-covered (fresh, deep snow) roads. | |
| The brake pedal moves and generates noises when TCS or VDC is activated due to rapid acceleration or sharp turn. | |
| The brake pedal vibrates and motor operation noises occur from the engine room after the engine starts and just after the vehicle starts. | This is normal, and it is caused by the ABS operation check. |
| Depending on the road conditions, the driver may experience a sluggish feel in the brake pedal. | This is normal, because TCS places the highest priority on the optimum traction (stability). |
| TCS may activate momentarily if wheel speed changes when driving where road friction coefficient varies, when downshifting, or when fully depressing accelerator pedal. | |
| The ABS warning lamp, VDC OFF indicator lamp and SLIP indicator lamp may turn ON when the vehicle is subject to strong shaking or large vibration, such as when the vehicle is rotating on a turntable or located on a ship while the engine is running. | In this case, restart the engine on a normal road. If the normal condition is restored, there is no malfunction. At that time, erase the self-diagnosis memory. |
| VDC may not operate normally or the ABS warning lamp, VDC OFF indicator lamp, and SLIP indicator lamp may illuminate when driving on a road that is extremely slanted (e.g., bank in a circuit course). | |
| A malfunction may occur in the yaw rate/side/decel G sensor system when the vehicle turns sharply, such as during a spin turn, axle turn, or drift driving, while the VDC function is OFF (VDC OFF indicator lamp illuminated). | |
| The vehicle speed will not increase even though the accelerator pedal is depressed, when inspecting the speedometer on a 2-wheel chassis dynamometer. | Normal (Deactivate the VDC/TCS function before performing an inspection on a chassis dynamometer.) |
| VDC OFF indicator lamp and SLIP indicator lamp may simultaneously turn ON when low tire pressure warning lamp turns ON. | This is not a VDC system error but results from characteristic change of tire. |

WHEEL SENSOR

< REMOVAL AND INSTALLATION >

[VDC/TCS/ABS]

REMOVAL AND INSTALLATION

WHEEL SENSOR

FRONT WHEEL SENSOR

FRONT WHEEL SENSOR : Exploded View

INFOID:000000007208043

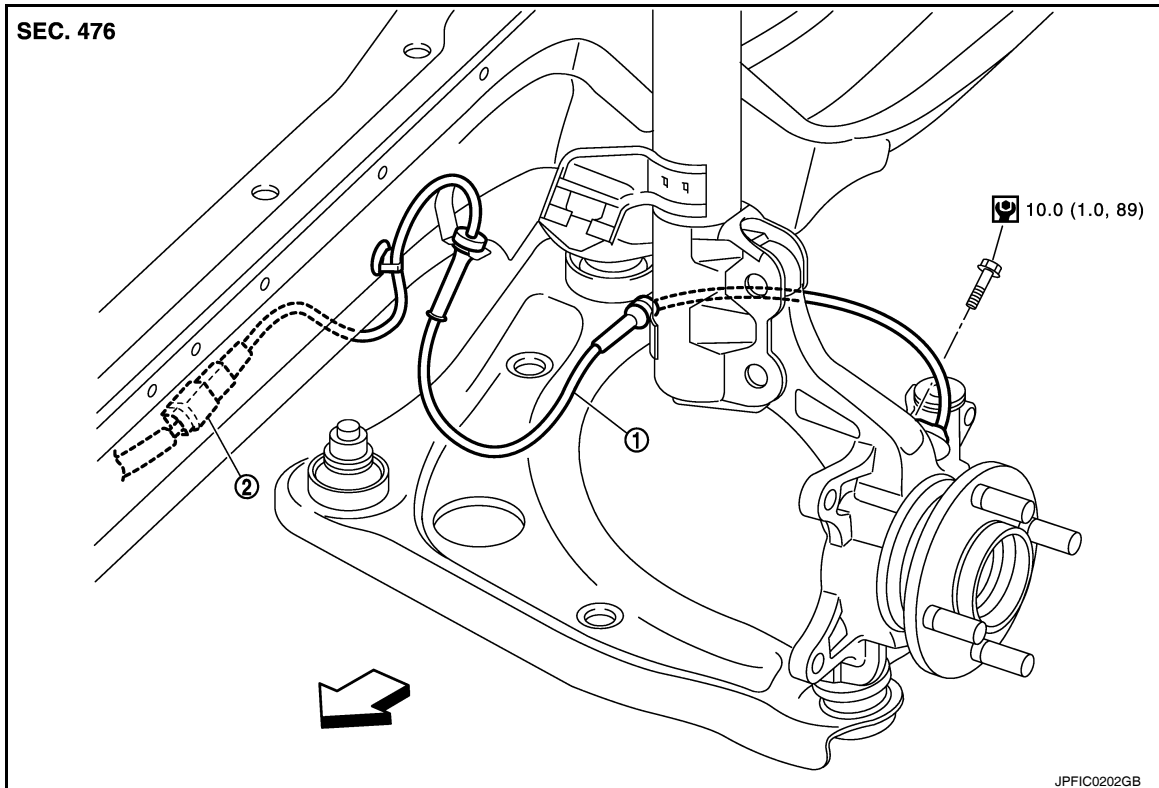

1. Front LH wheel sensor 2. Front LH wheel sensor harness connector ← Vehicle front

FRONT WHEEL SENSOR : Removal and Installation

INFOID:000000007208044

CAUTION:

- Be careful not to damage wheel sensor edge and sensor rotor teeth.
- When removing the front wheel hub, first remove the wheel sensor from the wheel hub. Failure to do so may result in damage to the wheel sensor wires, making the sensor inoperative.
- Pull out the wheel sensor, being careful to turn it as little as possible. Do not pull on the wheel sensor harness.
- Before installation, check if foreign objects, such as iron fragments, are adhered to the pick-up part of the sensor or to the inside of the hole in the wheel hub for the wheel sensor, or if a foreign object is caught in the surface of the mating surface for the sensor rotor. Fix as necessary and then install the wheel sensor.

REMOVAL

1. Remove tires.
2. Remove the fender protector (front). Refer to [EXT-26, "Removal and Installation"](#).
3. Remove front wheel sensor from steering knuckle.
4. Remove front wheel sensor harness from the vehicle.

INSTALLATION

Installation is in the reverse order of the removal.

CAUTION:

A

B

C

D

E

BRC

G

H

I

J

K

L

M

N

O

P

WHEEL SENSOR

< REMOVAL AND INSTALLATION >

[VDC/TCS/ABS]

Never twist front wheel sensor harness when installing front wheel sensor. Check that grommet (2) is fully inserted to bracket (1). Check that front wheel sensor harness is not twisted after installation.

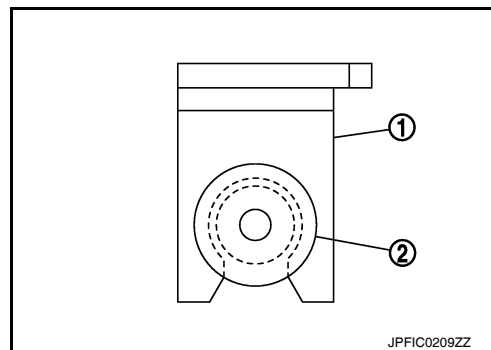

REAR WHEEL SENSOR

REAR WHEEL SENSOR : Exploded View

INFOID:000000007208045

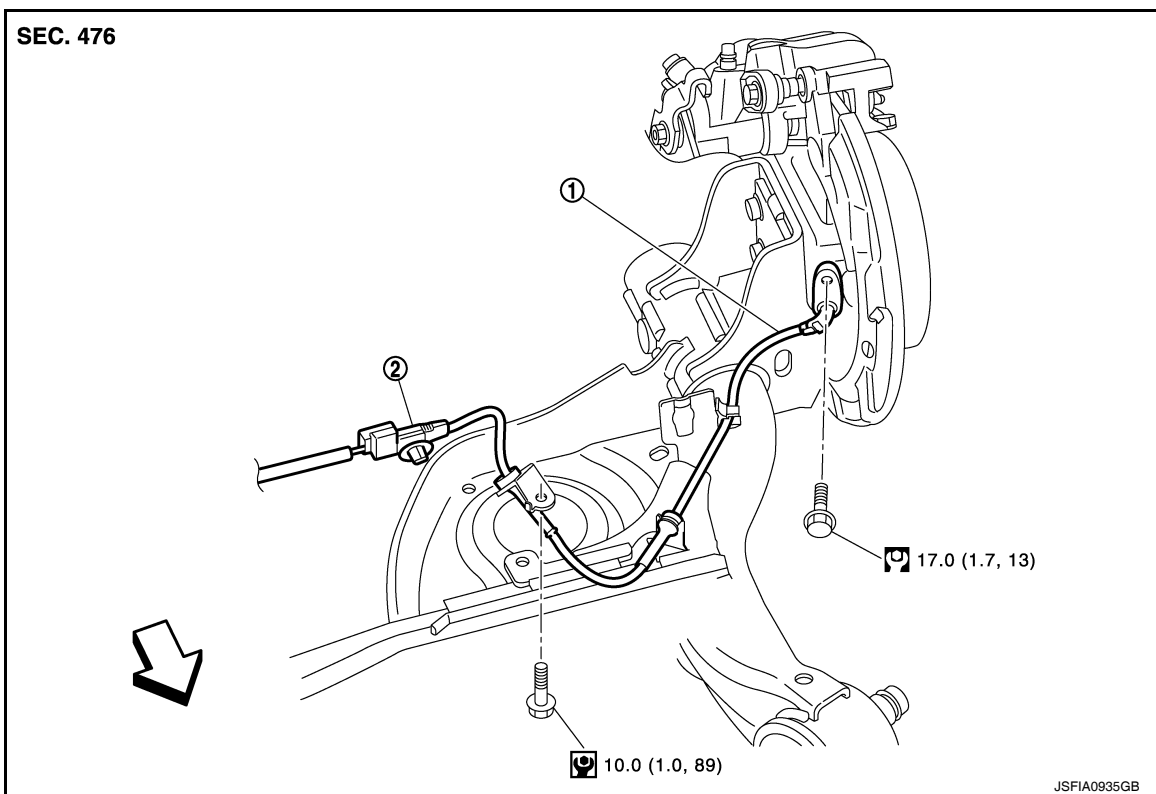

1. Rear LH wheel sensor 2. Rear LH wheel sensor harness connector ⇐ Vehicle front

REAR WHEEL SENSOR : Removal and Installation

INFOID:000000007208046

CAUTION:

- Be careful not to damage wheel sensor edge and sensor rotor teeth.
- When removing the front or rear wheel hub, first remove the wheel sensor from the wheel hub. Failure to do so may result in damage to the wheel sensor wires, making the sensor inoperative.
- Pull out the wheel sensor, being careful to turn it as little as possible. Do not pull on the wheel sensor harness.
- Before installation, check if foreign objects, such as iron fragments, are adhered to the pick-up part of the sensor or to the inside of the hole in the wheel hub for the wheel sensor, or if a foreign object is caught in the surface of the mating surface for the sensor rotor. Fix as necessary and then install the wheel sensor.

REMOVAL

1. Remove rear wheel sensor from back plate.
2. Remove rear wheel sensor harness from the vehicle.

WHEEL SENSOR

< REMOVAL AND INSTALLATION >

[VDC/TCS/ABS]

INSTALLATION

Installation is in the reverse order of the removal.

CAUTION:

Never twist rear wheel sensor harness when installing rear wheel sensor. Check that grommet (2) is fully inserted to bracket (1). Check that rear wheel sensor harness is not twisted after installation.

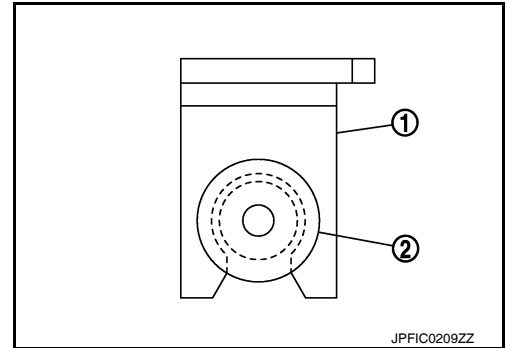

A
B
C
D
E

BRC

G
H
I
J
K
L
M
N
O
P

SENSOR ROTOR

< REMOVAL AND INSTALLATION >

[VDC/TCS/ABS]

SENSOR ROTOR

FRONT SENSOR ROTOR

FRONT SENSOR ROTOR : Removal and Installation

INFOID:000000007208047

REMOVAL

The front wheel sensor rotor is an integral part of the wheel hub and bearing assembly and can not be replaced individually. When replacing the front wheel sensor rotor replace the hub and bearing assembly. Refer to [FAX-9, "Removal and Installation"](#).

INSTALLATION

Refer to [FAX-9, "Removal and Installation"](#).

REAR SENSOR ROTOR

REAR SENSOR ROTOR : Removal and Installation

INFOID:000000007208048

REMOVAL

1. Remove the brake drum. Refer to [BR-41, "Exploded View"](#).
2. Remove the sensor rotor from brake drum. Refer to [BR-43, "Disassembly and Assembly"](#).

NOTE:

Do not reuse rear sensor rotor.

INSTALLATION

Installation is in the reverse order of removal.

ABS ACTUATOR AND ELECTRIC UNIT (CONTROL UNIT)

< REMOVAL AND INSTALLATION >

[VDC/TCS/ABS]

ABS ACTUATOR AND ELECTRIC UNIT (CONTROL UNIT)

Exploded View

INFOID:000000007208049

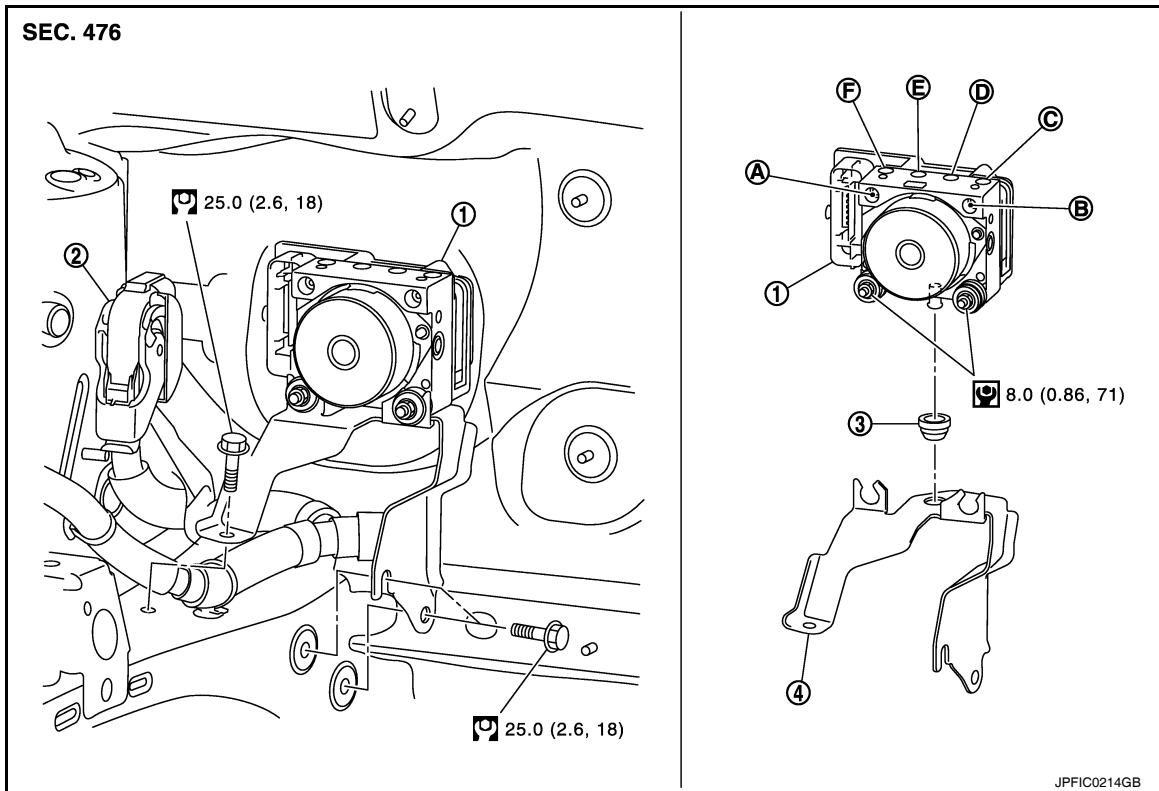

- | | | |
|--|--|------------------------------------|
| 1. ABS actuator and electric unit (control unit) | 2. ABS actuator and electric unit (control unit) harness connector | 3. Bushing |
| 4. Bracket | A. To master cylinder secondary side | B. To master cylinder primary side |
| C. To rear LH wheel cylinder | D. To front RH caliper | E. To front LH caliper |
| F. To rear RH wheel cylinder | | |

Removal and Installation

INFOID:000000007208050

CAUTION:

Be careful of the following:

- Before servicing, disconnect the battery cable from negative terminal.
- To remove brake tubes, use a suitable tool (flare nut wrench) to prevent flare nuts and brake tubes from being damaged. To install, use suitable tool (flare nut torque wrench).
- Do not apply excessive impact to ABS actuator and electric unit (control unit), such as by dropping it.
- Do not remove and install ABS actuator and electric unit (control unit) by holding harness.
- After work is completed, bleed air from brake tubes. Refer to [BR-12, "Bleeding Brake System"](#).
- After installing harness connector on the ABS actuator and electric unit (control unit), make sure connector is securely locked.

NOTE:

When removing components such as hoses, tubes/lines, etc., cap or plug openings to prevent fluid from spilling.

REMOVAL

1. Disconnect battery cable from negative terminal.
2. Disconnect ABS actuator and electric unit (control unit) harness connector.
3. Loosen flare nut of brake tube using a flare nut wrench, and then remove brake tube from ABS actuator and electric unit (control unit). Refer to [BRC-107, "Exploded View"](#).

ABS ACTUATOR AND ELECTRIC UNIT (CONTROL UNIT)

< REMOVAL AND INSTALLATION >

[VDC/TCS/ABS]

4. Remove ABS actuator and electric unit (control unit) and bracket.
5. Remove bracket and bushing from ABS actuator and electric unit (control unit), if necessary.

INSTALLATION

Installation is in the reverse order of removal.

CAUTION:

If ABS actuator and electronic unit (control unit) is replaced, after installation, adjust position of steering angle sensor. Refer to [BRC-53, "Work Procedure"](#).

VDC OFF SWITCH

< REMOVAL AND INSTALLATION >

[VDC/TCS/ABS]

VDC OFF SWITCH

Removal and Installation

INFOID:000000007630957

REMOVAL

1. Remove the instrument lower panel LH. Refer to [IP-14. "Exploded View"](#).
2. Release pawls (A) using suitable tool and remove the VDC OFF switch.

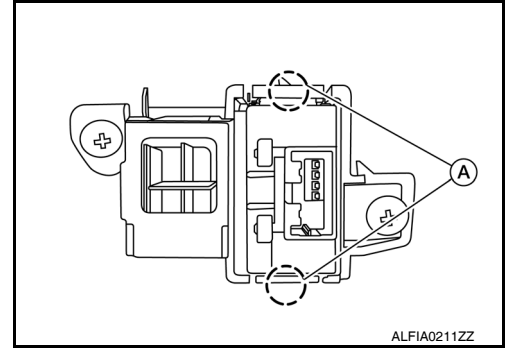

INSTALLATION

Installation is in the reverse order of removal.

A
B
C
D
E
BRC
G
H
I
J
K
L
M
N
O
P

STEERING ANGLE SENSOR

< REMOVAL AND INSTALLATION >

[VDC/TCS/ABS]

STEERING ANGLE SENSOR

Removal and Installation

INFOID:000000007630858

REMOVAL

1. Remove the spiral cable. Refer to [SR-7, "Removal and Installation"](#).
2. Remove the screws (A) and release the clips (B) then remove the steering angle sensor (1) from the spiral cable (2).

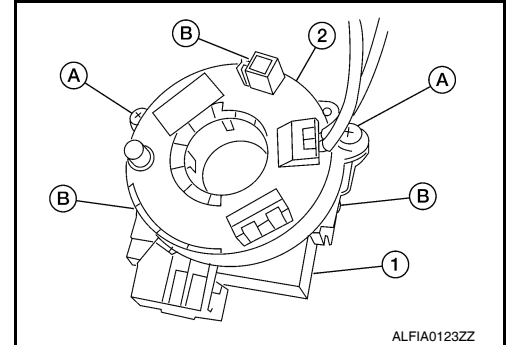

INSTALLATION

Installation is in the reverse order of removal.

- Reset the neutral position of the steering angle sensor. Refer to [BRC-54, "Work Procedure"](#).

CAUTION:

Any time the steering angle sensor is removed and installed or replaced, the neutral position of the steering angle sensor must be reset.